

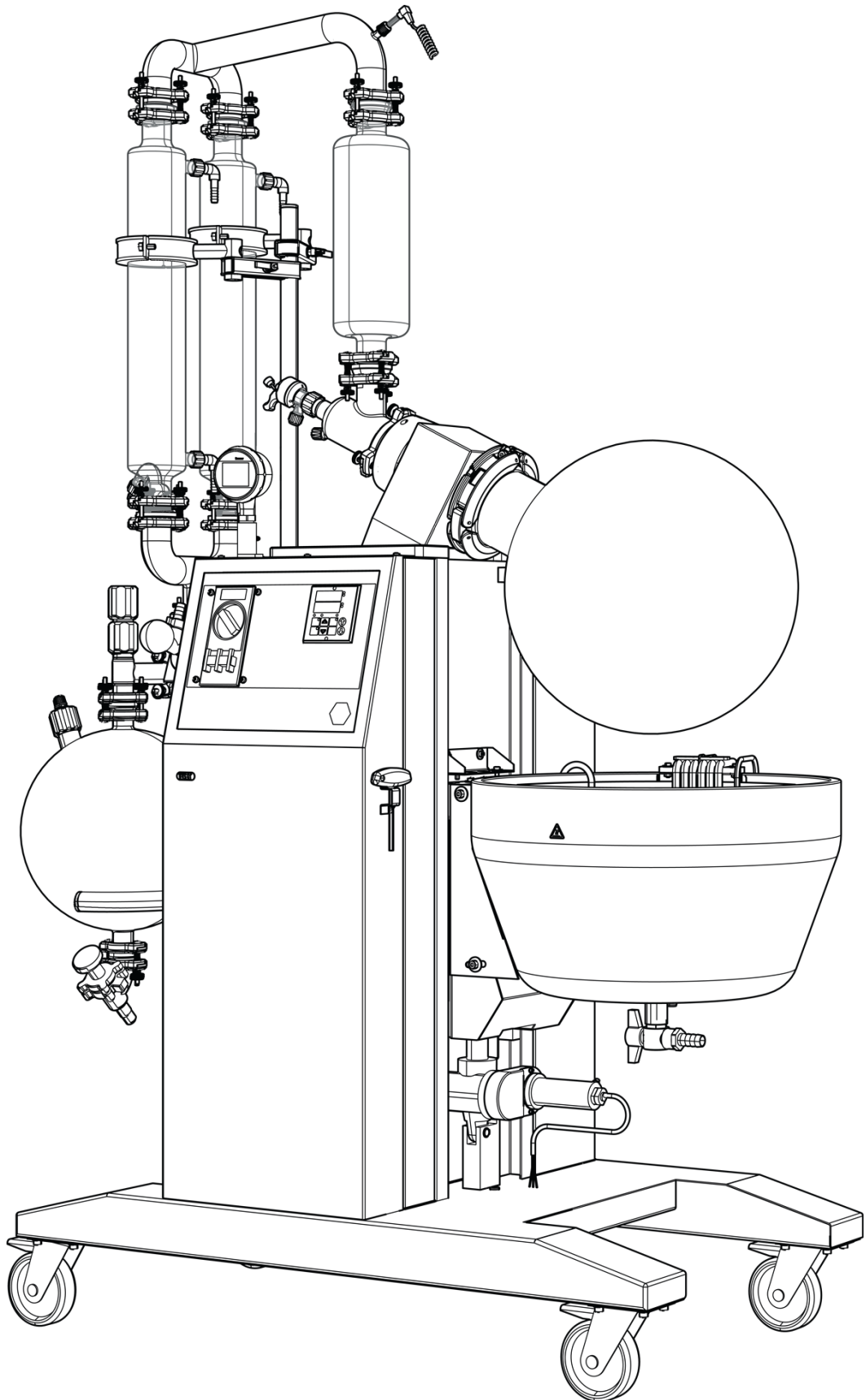

Rotavapor® R-250 EX

Operation Manual



Imprint

Product Identification:
Operation Manual (Original), Rotavapor® R-250 EX

096806S en

Publication date: 09.2021

BÜCHI Labortechnik AG
Meierseggstrasse 40
Postfach
CH-9230 Flawil 1

E-Mail: quality@buchi.com

BUCHI reserves the right to make changes to the manual as deemed necessary in the light of experience; especially in respect to structure, illustrations and technical detail.

This manual is copyright. Information from it may not be reproduced, distributed, or used for competitive purposes, nor made available to third parties. The manufacture of any component with the aid of this manual without prior written agreement is also prohibited.

Table of Contents

1	Scope of Delivery	4	Lowering the Bath Automatically	23
2	Safety	3	5.3 Vacuum Controller	24
2.1	Symbols	5	5.4 Selection of Distillation Temperature	28
2.2	Responsibilities of the Operator	5	5.5 List of Solvents	29
2.3	Authorized Use	5	5.6 Troubleshooting	30
2.4	Unauthorized Use	6	5.7 Resetting the Safety Temperature Cutoff	31
2.5	Basic Dangers	6	5.8 Error Messages	32
2.6	Safety Precautions	6	6 Maintenance	33
2.7	Modifications	7	6.1 Cleaning	33
3	Function	9	6.2 Dismantling/Assembling the Snap Flange Coupling	34
4	Putting into Operation	10	6.3 Removing/Inserting the Evaporating Flask Seal	35
4.1	Installation Location	10	6.4 Changing the Seals to the Distribution Head	36
4.2	Unpacking	10	6.5 Installing and Removing the Vacuum Seal	36
4.3	Connecting to the Source of Energy	11	6.6 Testing for Leaks	37
4.4	Setting Up the Support Rod	11	6.7 Customer Service	37
4.5	Fitting and Removing the EasyClamp Connection	12	7 Taking out of Operation	38
4.6	Installation of the Receiving Fixture	13	7.1 Storage	38
4.7	Installation of the Reflux Glass Assembly	14	7.1 Packing / Transport	38
4.8	Installation of the Descending Glass Assembly	15	7.1 Waste Transport	38
4.9	Attaching and Removing Flasks	16	8 Spare Parts and Accessories	39
4.10	Operating the Shut-off tap	18	8.1 Spare Parts, Glass Assemblies R, RB	39
4.11	Operating the Inlet Valve	18	8.2 Spare Parts, Glass Assemblies D, D3	39
4.12	Flask Suction (Optional)	19	8.3 Spare Parts, Drip Tray	39
4.13	Connections to the Vacuum and Cooling Medium	20	8.4 Seals, Tools	39
4.14	Heating Medium	21	8.5 Accessories	39
4.15	Checking the Installation	21	8.6 Hose Connections	39
5	Operation	22	9 Appendix	47
5.1	Layout of Operating and Display Elements	22	9.1 Technical Data	47
5.2	Setting the Maximum Setpoint Temperature and		9.2 Materials Used	47
			9.3 Declaration of Conformity	48



Read this Operating Manual through carefully before using the Rotavapor **R-250 EX**. Always keep these Instructions readily available in the immediate vicinity of the unit so that they make be consulted at any time.

Chapter 2 contains important safety rules which must be observed to ensure the safe operation of the rotary evaporator.

We reserve the right to make technical changes without prior notification. No portion of this Operating Manual may be reproduced, processed using electronic or optical systems, duplicated, or distributed in any form without the prior written approval of BÜCHI Labortechnik AG.

All rights reserved. © BÜCHI Labortechnik AG, 2000, 2001

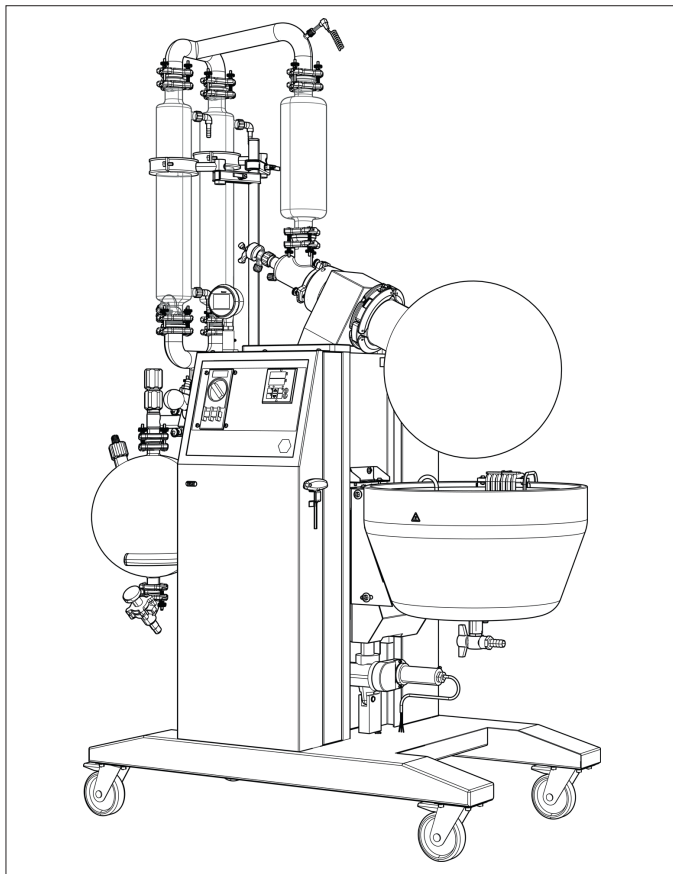

Fig. 1.1: R-250 EX, Overall view

1 Scope of Delivery

Component

1	Chassis, complete, with
	Control, flameproof enclosure
	Intrinsically safe control panel
	Rotation drive, flameproof enclosure
	Main switch, lockable
	Bath lift
	Heating bath, complete
1	Glass assembly, comprising
	20 or 50 ltr. evaporating flask
	Condensation assembly
	Receiving assembly

Table 1: Scope of delivery

Standard accessories, comprising	Ordering No.
1 Clamping tool	
1 Wrench	
Hoses, complete	
1 Installation tool	
1 Instruction Manual	
German	96805
English	96806
French	96807
Italian	96808
Spanish	96809
1 Documentation CD	96817

Table 2: Standard accessories

Marking

CE₀₁₀₂  II 2 G EEx de ia [ia] IIC T3-T4

2 Safety

This unit has been built in accordance with the latest state of the art and with recognized rules of safety. Nevertheless there are certain risks and dangers entailed with this unit:

- whenever the unit is operated by individuals who lack sufficient training;
- whenever the unit is used for some purpose other than its authorized use.

2.1 Symbols



Stop

Information on dangers that can cause serious material damage and severe personal injuries or death.



Warning

Information on dangers that can be injurious to one's health or cause material damage.



Note

Information pointing out technical requirements. A failure to observe such information can lead to malfunctions, uneconomical operation, and losses in production.

2.2 Responsibilities of the Operator

This unit may only be used by technical staff and by individuals who, based on their training or their professional experience, have a good understanding of the dangers that can arise from the its operation.

Staff who do not have this training and individuals who are currently in training must be given careful instructions. This Operating Manual should be used as the basis for such training.

2.3 Authorized Use

The rotary evaporator has been designed for use in technical laboratories and in production. It is authorized for use in applications that work with the evaporation and condensation of solvents.

It is used for:

- Evaporation of solvents and suspensions
- Drying of powders and granulates
- Re-crystallization
- Reactions under reflux
- Synthesis and Cleaning of refined chemicals
- Recycling and concentration of solvents

The authorized use of the Rotavapor also includes its care, upkeep, and careful handling in accordance with the provisions in this Operating Manual.

2.4 Unauthorized Use

Any use other than those indicated above, and any use that is not in conformity with the Technical Data is considered to be misuse. The operator himself bears sole responsibility for all damage or injuries arising from any such use.



The following applications in particular are strictly forbidden:

- The production and processing of materials that can cause spontaneous reactions, e.g., explosives;
- Working without the evaporation flask being immersed in the water bath (risk of breakage);
- The drying of hard, brittle materials (e.g., stones, soil samples) that might cause damage to the receiving flask;
- Sudden shock-cooling of the evaporating flask.



The Rotavapor R-250 EX is not intended for work done under overpressures.

2.5 Basic Dangers

Basic dangers arise when working with the following:

- The hot water or oil bath (risk of being scalded);
- Contaminated solvents that produce residues from distillation which could cause spontaneous reactions (e.g., metal hydrides);
- Solvents that can produce peroxides (risk of explosions);
- Mixtures with unknown compositions or contamination;
- Damaged glassware;
- Electrostatic charges while working, e.g., during the transfer of combustible solutions and while drying powders;
- Temperatures of coolants that lie below the freezing point of the distillate (A clogging of the distillate cooler due to freezing out can result in an overpressure).

2.6 Safety Precautions

All regional and local laws and regulations must be observed.

The Rotavapor has been grounded internally to dissipate any electrostatic charges on it.

It is always mandatory to wear personal protective gear such

as **protective eyewear** and **protective clothing**.



The machine must never be rotated without the snap flange coupling being closed.

No distillation may be started unless the evaporating flask is immersed in the bath. There is always the risk that the neck of the flask might break off due to the great weight involved. There is a risk of becoming scalded while changing evaporating flasks. Wearing gloves prevents this.

Check the glass components regularly for possible damage, spreading impact marks, or cracks.



Never interrupt the grounding conductor (protective conductor). Otherwise there will be the risk of an electrical shock!

The operator bears responsibility for providing proper instruction of his operating staff. To aid him in doing this, translations of this Instruction Manual are also available in several other languages. As an integral component of the rotary evaporator, this Instruction Manual must be readily available at all times to the operating staff at the location where they are using the unit.

The operator must inform the manufacturer immediately of any and all events relevant to safety that occur in his use of this equipment.

2.7 Modifications

No modifications are permissible without consulting with and obtaining the written approval of the manufacturer.

No glass assemblies other than those recommended by the manufacturer may be used, nor may any glass components be put together arbitrarily.



Only those components of the rotary evaporator intended for fulfillment of its function may be installed in or removed from the unit. This may be done either by hand, or with the use of the tool supplied along with the unit. The removal of safety devices or covers using some commercially available tool is — other than for authorized commissioning personnel — strictly forbidden. Contact with parts that are electrically live may result in fatal injury!

2.8 Information on explosion protection

The R-250 EX rotary evaporator must not be operated in Zone 0 of ex-protected areas.



It is not permitted to open the housing, in particular the flameproof enclosure, and this task may only be carried out by trained service personnel.

The user may not disconnect, reconnect or in any way change the function of the electrical equipment and installation fittings. Changes may only be made by the manufacturer.

The acceptance inspection is made by an expert.

3 Function

A vacuum rotary evaporator is used for quick single-stage distillations that treat the product gently. The process is based on the evaporation and condensation of solvents in a rotating evaporating flask.

It is possible to work under a vacuum to ensure gentler treatment of the product and increase productive output.

Distillation may be done either under a vacuum or at atmospheric pressure.

A secure tightness is only guaranteed in the low pressure range.

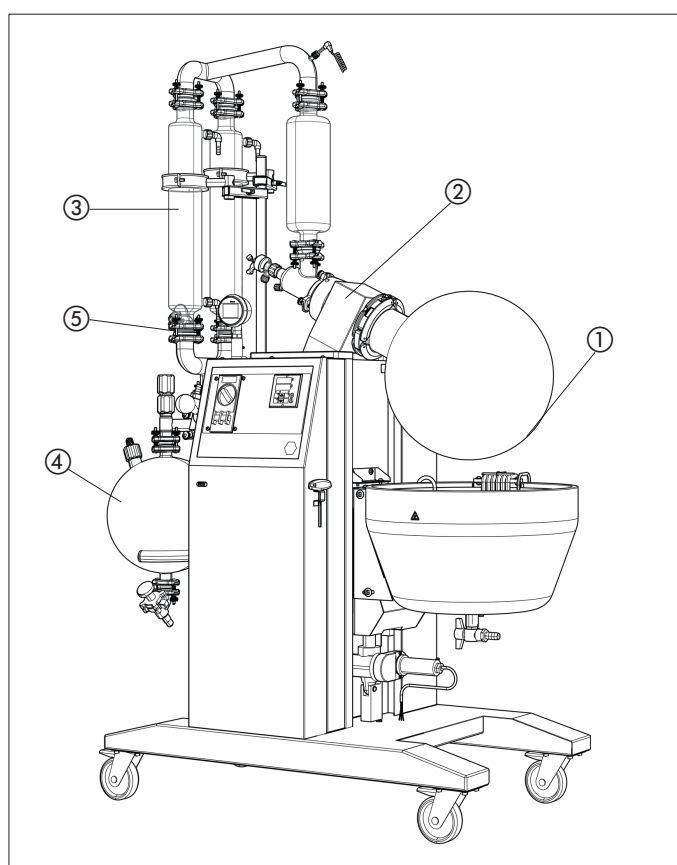

Fig. 3.1: Functional elements of the R-250 EX

① Evaporation Zone

The solvent in the evaporating flask is heated by the heating bath. The rotation of the evaporating flask ensures an intensive heat and mass transfer within the contents of the flask, forming a thin film of solvent on the inner surface of the flask. This combination of turbulence and film prevents local overheating and ensures high distillation speed.

② Rotary Drive

The drive unit ensures the uniform rotation of the evaporating flask.

③ Condensing Zone

The solvent vapor flows into the cooler at a high speed. This is where the energy in the solvent vapor is transferred to the cooling medium (e.g., water). The solvent condenses.

④ Receiving Flask

The receiving flask is used to collect the condensate.

⑤ Vacuum Connection

The system pressure is reduced so as to lower the boiling point of the solvent. The reduction in thermal loading that results ensures gentle treatment of the product and offers energetic advantages.



The pressure (vacuum) of distillation, the temperature of the heating bath, the rotational speed, and the size of the evaporating flask all affect the evaporation output. Refer to Chapter 5.3 for how to select the optimum conditions of distillation.

4 Putting into Operation



The danger zone around the Rotavapor R-250 EX can extend outward by up to 10 m. When working inside this danger zone, there is a risk of damaging the glass parts, which could cause them to implode.

4.1 Installation Location

Always set the unit up on a clean, stable, and flat surface. Never at a location where there is a great deal of personal traffic (breaking or broken glass) !

A check must always be made to ensure that the explosion-protection classification of the device is permissible for the ex-classification of the room. In particular, the zone allocation and the temperature class must agree.

The ambient temperature must be between 5° and 40°C.

The dimensions of the rotary evaporator are:

Height

- Reflux 2.45 m
- Bullfrog Reflux 2.10 m
- Descending 2.30 m

Width

1.40 m

Depth

- Single receiver 0.80 m
- Interchangeable receiver 0.85 m

4.2 Unpacking



Take care not to break the glass when opening cartons that contain glassware.

Look for any damage after unpacking. It is important that any damage in transit be identified right when unpacking. If necessary, make an immediate assessment of the situation (Notify the post office, the railroad, or the shipping company involved).

Save the original packing for possible transport at a later date.



The bath is fixed with a transportation security to the housing. Before lifting the bath, this security has to be screwed away

4.3 Connecting to the Source of Energy

The rotary evaporator may only be connected to the electrical supply by the trained person who has been assigned responsibility for this task. EN 50014 stipulates that, apart from the main cable being earthed, an equipotential bonding conductor must be connected in addition. This connection is on the back of the device approximately half way up.

The cooling medium must not exceed the maximum operating pressure of 2.7 bar abs. (shock-free).

4.4 Setting Up the Support Rod

- Place the support rod ① into the holders provided ②, ③ and fix it tight using the locking screw.
- Put on the positioning ring over the rod. (Glass assembly D3 has two positioning rings.)
- Lay the pivoting clamps on the top of the positioning ring. (Glass assembly D3 has two pivoting clamps on the upper ring and one pivoting clamp on the lower ring.)
- Fit the flask supports ④, including the positioning nut, on the lower support rod ⑤. Set the flask support with the positioning nut approx. 2 cm above the upper edge of the retainer.

4.5 Fitting and Removing the EasyClamp Connection

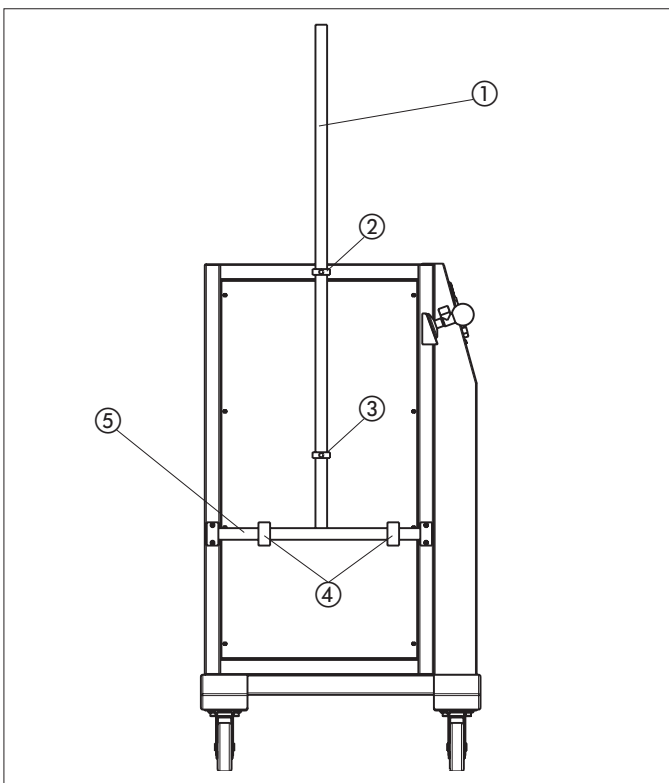

Fig. 4.1: Fitting the support rod



Fig. 4.2: Attachment of the EasyClamp



Fig. 4.3: Removal of the EasyClamp

Attachment of the EasyClamp

- Carefully lay the EasyClamp around the glass and fold the top and bottom segments together, closing them at their open connection point.
- Insert the bolt that does not have a spacer spring, and tighten the knurled nuts slightly.
- Tighten all knurled nuts uniformly by hand.

Note:

Always tighten the knurled nuts by hand and not to the block (with the spring pressed together completely). Otherwise the prestressing will be lost.

There must always be a gap of about 2 mm between the knurled nut and the support surface.

Removal of the EasyClamp

On all EasyClamp connections, **only the bolt without a spacer spring** has to be removed in order to open the connection.

- Release the knurled nuts on all (2 or 3) bolts until the springs have been relieved. Do not, however, screw the nut all the way off.
- On the bolt that does not have a spacer spring, release the knurled nut far enough (without removing it completely) so that the bolt can be tilted out and removed as a unit.
- At the connection point, which is now open, spread the top and bottom segments apart and carefully remove the EasyClamp.

4.6 Installation of the Receiving Glass Assembly

All glassware used must be intact, with no signs of cracks,



spreading impact marks, or other damage. Inspect the glassware visually before installing it.

Single receiver

- Insert the supporting ring ① into the connecting fitting ②.
- Secure the outlet valve ③ to the flask ④ using a DN 25 EasyClamp connection.
- Connect the branching piece ⑤ to the flask ④.
- Insert the shut-off tap ⑥ and tighten it firmly.

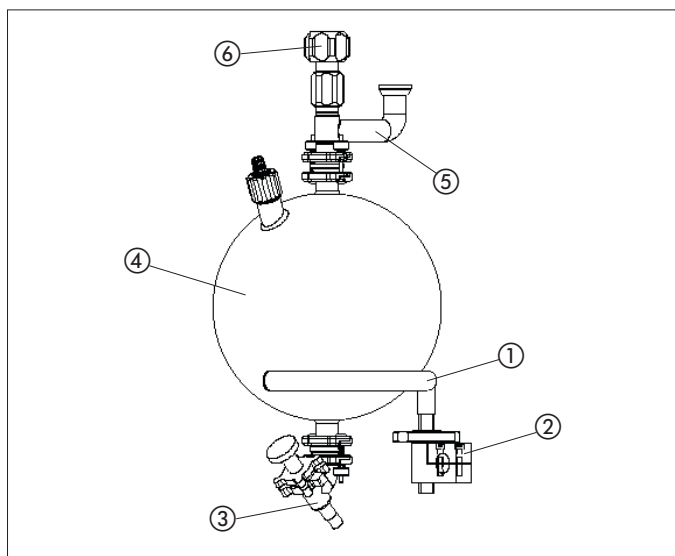

Fig. 4.4: Single receiver

Interchangeable receiver

- Insert the supporting rings ① into the connecting fitting ②.
- Secure the outlet valves ③ to the flask ④ using a DN 25 EasyClamp connection.
- Connect each bracket ⑤ to the flask ④ and insert the branching piece ⑥. Connect using four EasyClamp connections.
- Insert the shut-off tap ⑦ and tighten it firmly.

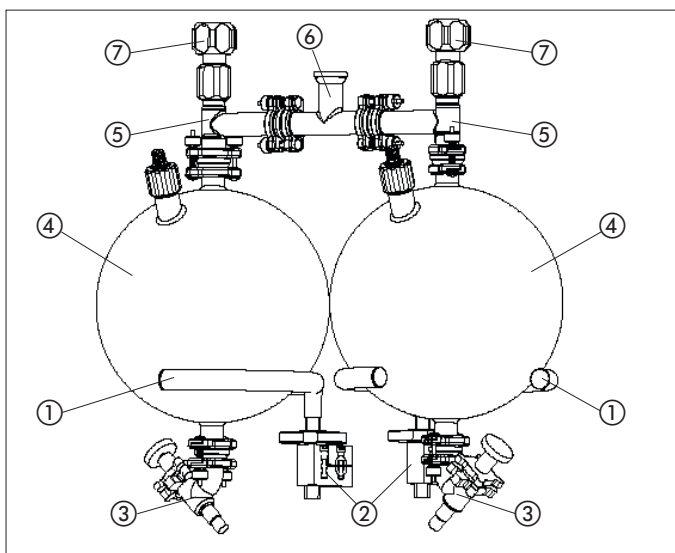

Fig. 4.5: Interchangeable receiver

4.7 Installation of the Reflux Glass Assembly

All glassware used must be intact, with no signs of cracks,



spreading impact marks, or other damage. Inspect the glassware visually before installing it.

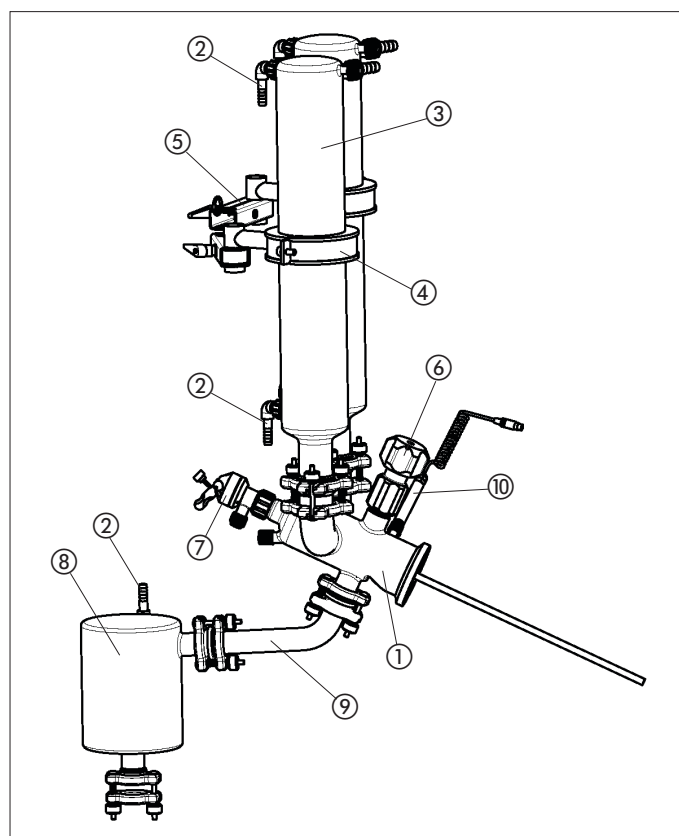

Fig. 4.6: Reflux glass assembly

- Fix the reflux distribution head ① in position on the gear head using a DN 70 EasyClamp connection.
- Fit the cooling water hose nipples ② to both coolers ③.
- Introduce both coolers ③, together with the cooler holders ④, into the pivoting clamps ⑤ and connect them to the distribution head (2 x DN 40 EasyClamp connections).
- Align the coolers ③ in a vertical position and fix in place with the pivoting clamps ⑤.
- Screw the shut-off tap ⑥ into the distribution head ① and tighten it firmly.
- Insert the inlet tap ⑦ into the distribution head and tighten the SVL 30 nut.
- Place the condensate cooler ⑧ on the drip tray and connect it using the EasyClamp connection. Fit the connecting pipe ⑨ between the condensate cooler and the distribution head ① and secure it (2 x DN 25 EasyClamp connections).
- Screw the temperature sensor ⑩ into the distribution head ①.
- Tighten all EasyClamp connections evenly and in parallel.
- Turn the positioning nut to raise the flask support. Connect the receiving flask to the condensation flask.

4.8 Installation of the Descending Glass Assembly

All glassware used must be intact, with no signs of cracks, spreading impact marks, or other damage. Inspect the glassware visually before installing it.

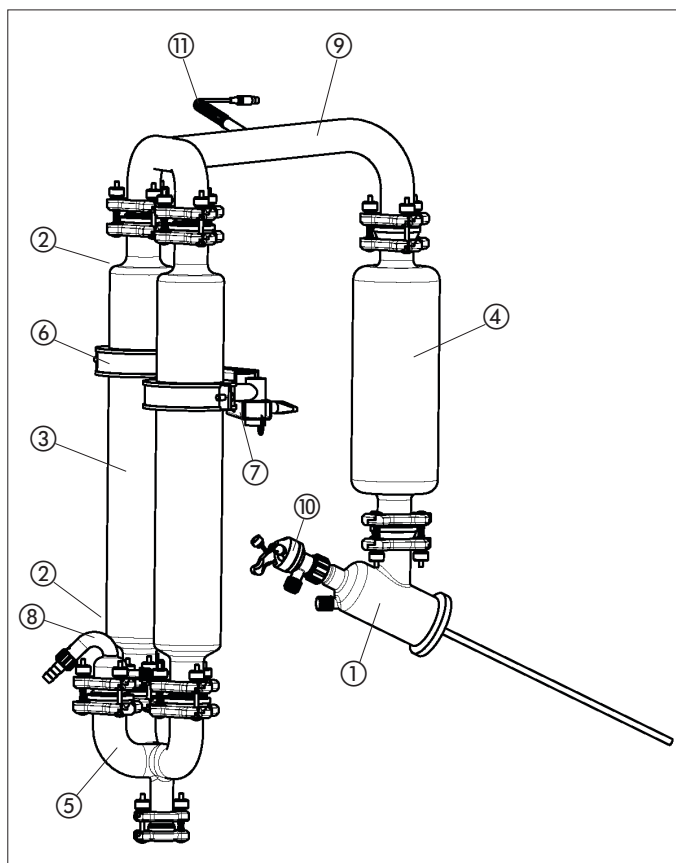

Fig. 4.7: Descending glass assembly

- Fix the descending distributor head ① in position on the gear head using the DN 70 EasyClamp connection.
- Fit the cooling water hose nipples ② to the two or, if appropriate, three coolers ③.
- Put the expansion vessel ④ onto the distribution head ① and secure it with the DN 40 EasyClamp connection.
- Fit the three-way fitting ⑤ onto the receiver using the DN 25 EasyClamp connection.
- Secure the cooler holder ⑥ to the two or three coolers ③, as appropriate, and insert in the pivoting clamps ⑦.
- Fit the vacuum connector ⑧ or the third cooler.
- Fit the branching piece ⑨ on the cooler ③ and the expansion vessel ④ and connect it using the EasyClamp connection. Align the glass components in a vertical position and secure them using the pivoting clamps ⑦.
- Fit the inlet tap ⑩ into the distribution head and tighten the SVL 30 nut.
- Screw the temperature sensor ⑪ into the branching piece ⑨.
- Tighten all EasyClamp connections evenly and in parallel.
- Turn the positioning nut to raise the flask support. Connect the bracket of the receiving flask to the condensation flask.

4.9 Attachment and Removal of the Flask

Attaching the flask

- With the snap flange coupling open, place the flask in position (by hand, using the manual flask handler or the crane).



Fig. 4.8: Fitting the flask

- Close the first segment of the snap flange coupling. (The hook must latch in.)
- Close the second segment of the snap flange coupling using the closure screw that can be folded down to connect the two segments.



Fig. 4.9: Closing the snap flange coupling

- Tighten the closure screw with ca. 4 Nm (to prevent glass breakage) using the hexagon wrench supplied.

Removing the flask

- Slacken off the closure screw using the hexagon wrench.
- Support the flask by hand or using the manual flask handler and then carefully lift up the closure screw.



Fig. 4.10: Tightening the snap flange coupling



Fig. 4.11: Releasing the snap flange coupling

- Push in the hook to release the second segment and fold it outwards.



Fig. 4.12: Opening the snap flange coupling

- Lift the flask out at the top and remove it.

4.10 Operating the Shut-off tap

The shut-off tap is of a special design. It does not have a continuous thread on its inside for tightening it, but rather a sliding plane with two fixed latching positions. The closing pressure when it is in a closed position is provided by a prestressed spring.



Fig. 4.13: Removing the flask

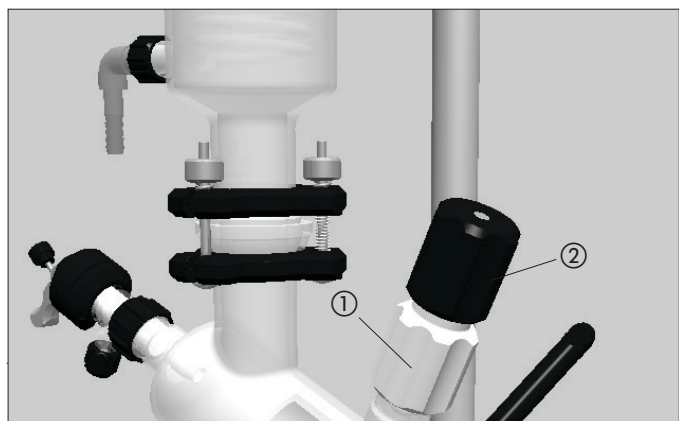

Fig. 4.14: Shut-off tap

- Insert the shut-off tap in the distribution head or branching piece and turn the white lower section of the grip ① clockwise until the tap is tightly seated.
- To open:
Turn the black upper section of the grip ② clockwise until the shut-off tap latches into the first position. If the opening is not large enough, continue turning until the tap reaches the second latching position.

4.11 Operating the Inlet Valve

The inlet valve is also closed by an integrated spring, which applies contact pressure between the PTFE and the ground-glass joint. The valve can be opened and closed by operating the lever manually. The setting screw on the lever permits precise continuous metering or venting.

4.12 Flask Outlet Suction (Optional)

- A 10 mm dia. PTFE hose is routed from the inside through the SVL 15 threaded opening ① on the distributor head and the threaded connection is tightened.
- The hose is then positioned by inserting it into the evaporating flask.

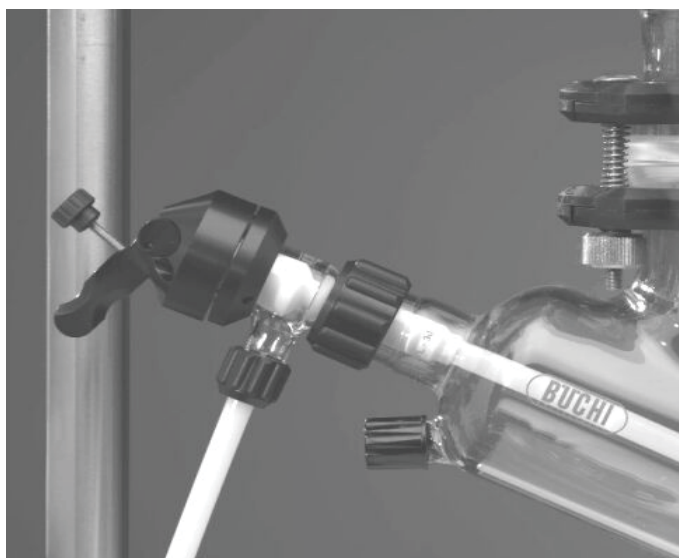
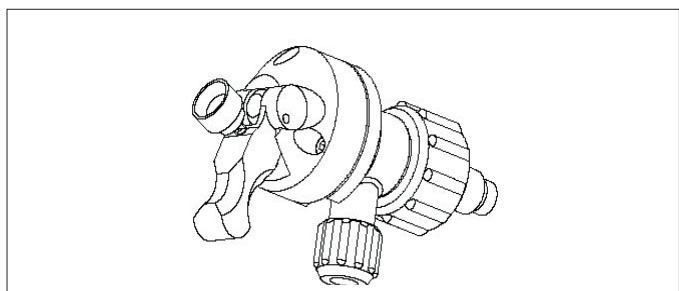

Fig. 4.15: Inlet tap

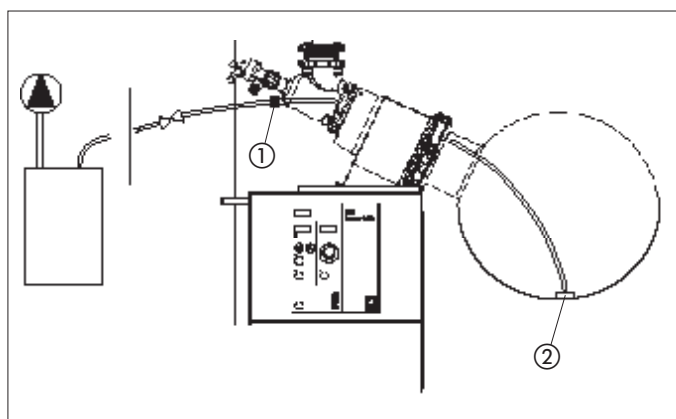

Fig. 4.16: Flask suction (diagram)

- A PTFE-encapsulated magnet ② is fitted to the front tip of the hose. A second magnet ③ is moved from the outer surface of the flask towards the tip of the hose until the magnets attract each other.
- By moving the outer magnet, the hose can be guided to any position in the flask and the entire contents can be siphoned off so that nothing remains in the flask.
- The hose is connected to a container and this is connected to a vacuum source. (Not included in the scope of delivery.)

4.13 Connections to the Vacuum and Cooling Medium

Vacuum

The Rotavapor R-250 EX is connected directly from the condensation unit to the vacuum source.



Fig. 4.17: Positioning the tip of the hose with the magnet

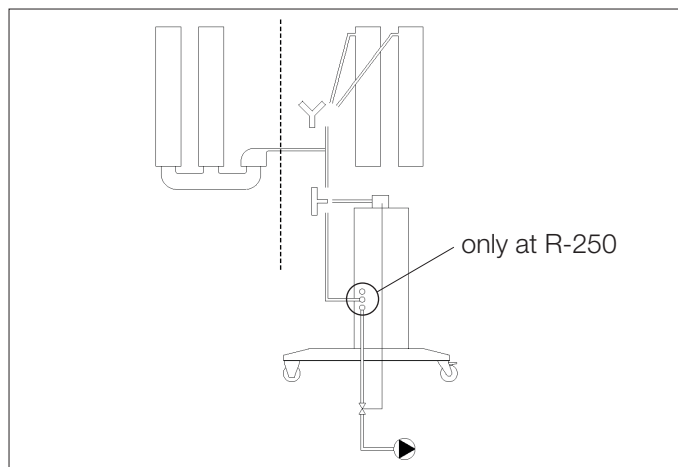

Fig. 4.20: Vacuum hoses

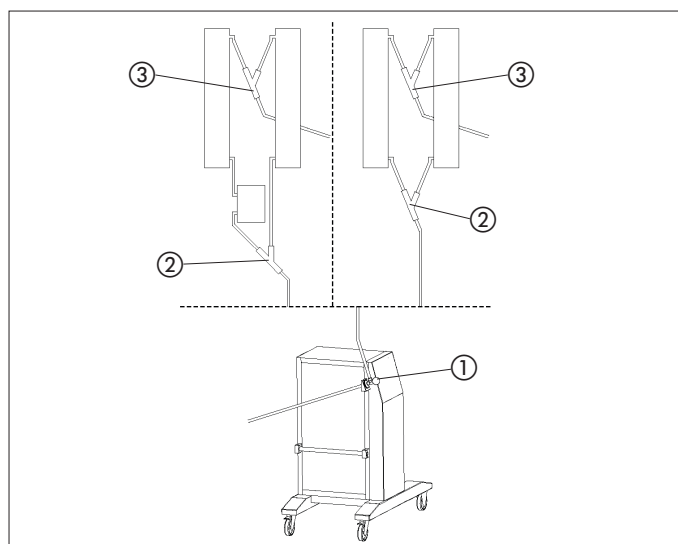

Fig. 4.21: Cooling water hoses

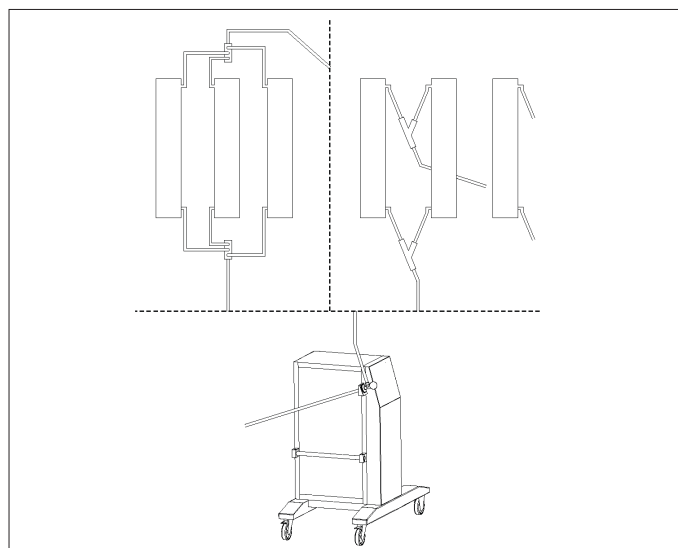

Fig. 4.22: Cooling water hoses: versions with third cooler

For the reflux glass assembly both condensers are connected to the vacuum hose via a Y-piece.

In the case of the descending glass assembly the vacuum hose is connected at the vacuum connector or at the third cooler.

Cooling medium

The cooling medium is connected at the valve fittings ①. The flow is adjusted by means of the tap. In the case of the reflux glass assembly, the distillate cooler is connected to one cooler from the valve ① via a Y-piece ② and the second cooler is connected in parallel. Finally, the two condensers are connected via a Y-piece ③ and the cooling medium is returned at the wide hose nipple.

In the case of the descending glass assembly, the cooling medium is distributed between the two condensers from the valve via a Y-piece ② and is then returned via a second Y-piece ③.

A list of the supplied hoses with Part Numbers can be found in Chapter 8.6.

If a third cooler fitted downstream is used, it is connected in parallel across a special water distributor head. A second cooling circuit at a lower temperature can also be used so that the third cooler becomes a cold trap.

4.14 Heating Medium

The level sensor is designed for temperatures up to max. 150°C. Higher temperatures cannot be obtained with the unit.

Never operate the heating bath when there is no heating medium in it!



Suitable heating media include:

- Water (some Borax should be added when using deionized water).
- Heat transfer oils suitable for use at temperatures up to 160° C (e.g., Ucon HTF 14, Fluka AG).
- Water-soluble polyethylene glycol (e.g., Polyethylene glycol 600, Fluka AG).

After the oil bath has been standing opened for a prolonged period, condensation water can collect on the bottom. When the bath is used again, it must be heated above 100°C with rotating flask in order to drive the water out.

4.15 Checking the Installation



After installation has been completed and before running the first distillation, check to make sure that the installation has been carried out correctly.

- Inspect the glass for possible damage.
- Check that all connections (cooling medium, vacuum) have been fixed properly in position.
- Check that the flask is securely mounted and cannot be moved at the snap flange coupling.
- Check for leaks in the vacuum system (see Chapter 6, Maintenance).
- When the unit is switched on, the version of the software is displayed and a visual check of the alarm LED is made.

5 Operation

Make sure that the unit has been commissioned properly as described in Chapter 4.

5.1 Layout of Operating and Display Elements

The R-250 EX is operated via the main switch which can be secured to prevent it from being switched on and the control panel which has an intrinsically safe design („i”). A vacuum display is also located on the front panel.

The operating unit is shown in Figure 5.1. It consists of two digital displays and eight operating buttons.

① Display 1: Actual bath temperature and setpoint bath temperature (The mode is displayed on the side LED.5)

② Display 2: Rotation speed and vapor temperature (The mode is displayed on the side LED.)

Heater

③ Heater on/off (displayed by LED)

④ When the heater is warming up, the LED illuminates

⑤ Activating the setpoint bath temperature Setting: The display ① switches to setpoint mode

⑥,⑦ Setting the bath temperature setpoint. If no entry is made within 2 seconds, the display returns to the actual bath temperature.

⑧ The red LED illuminates if the over-temperature protection has been triggered.

Rotation

⑨ Rotation on/off (shown by LED)

⑥,⑦ The rotation speed can be changed using these two pushbuttons.

⑩ In “Display Mode” the information shown on the display ② changes between the rotation speed and the vapor temperature.

Bath lift

⑪, ⑫ These buttons lower and raise the bath, respectively.

When the unit is switched off or in the event of a power failure, the bath can be lowered automatically so that the evaporating flask is always separated from the source of heat.

Do not use the main switch to lower the bath with the battery, because the voltage of the battery could be too low in case of a power failure.

5.2 Setting the Maximum Setpoint Temperature and

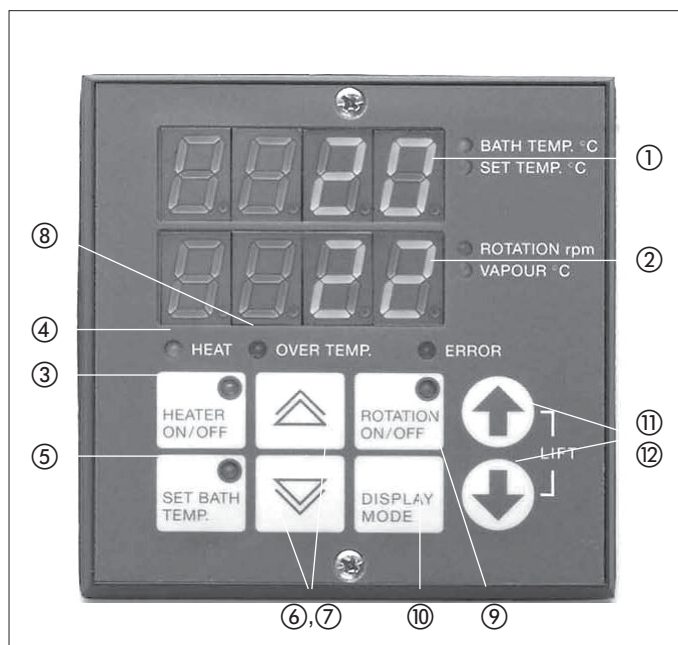

Fig. 5.1: Intrinsic safe operating unit of the R-250 EX



Lowering the Bath Automatically

Setting the Maximum Setpoint Temperature

- The input mode of the maximum setpoint temperature is activated by pressing the “Set Temp.” button ⑤ and simultaneously turning on the main switch.
- The required figure is set by pressing the “SET UP” and “SET DOWN” buttons ⑥,⑦.
- The entry is not saved until the “Set Temp.” button ⑤ is pressed. The unit is then switched into operating mode.

Setting the option for automatic lowering of the bath in the event of a power failure

- This option is activated by pressing the “Lift down” button ⑫ and simultaneously turning on the main switch.
- It is indicated on the display ② whether the bath is moving down (on) or not (off).
- It is possible to switch between these two options by pressing the “Lift down” button ⑫.
- The entry is not saved until the “Set Temp.” button ⑤ is pressed. The unit is then switched into operating mode.

If the option is activated, the bath is automatically lowered when the equipment is switched on. This ensures that, if there is a short power failure, the bath will be lowered.

If this option is not activated, in case of a power failure, the product can be overheated.





Fig. 5.3: Vacuum Controller

5.3 Vacuum Controller

Operation

The vacuum controller is operated by its touch screen. To control the vacuum in the Rotavapor® you need to set two values. The lower vacuum level (Relay 1 set point) is the ultimate vacuum that has to be reached. When reaching the upper vacuum level (Relay 1 reset point) the vacuum valve opens again. In between these two levels the vacuum in the system is being controlled.

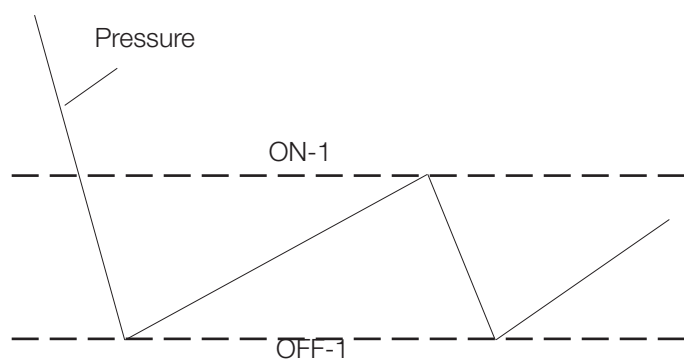







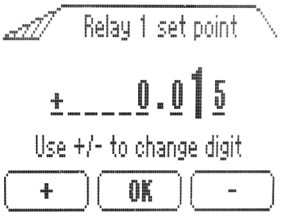
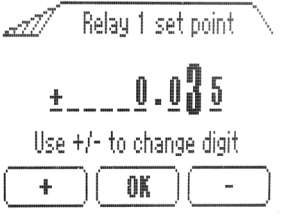

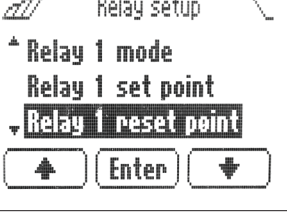

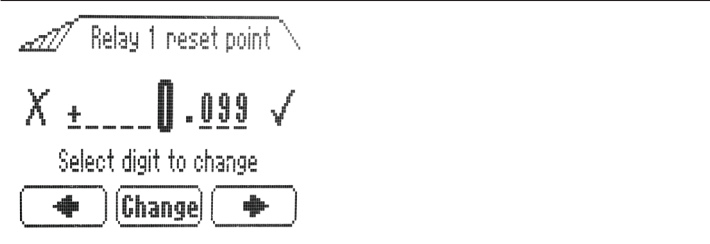
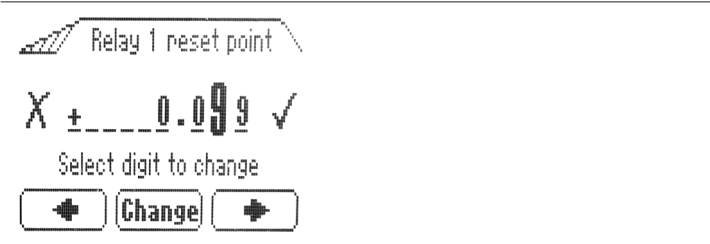
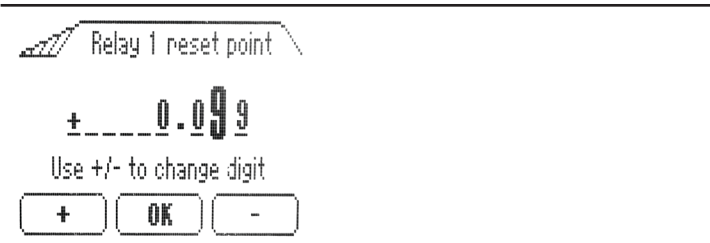
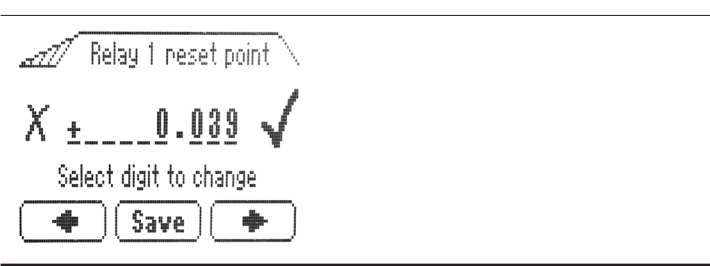
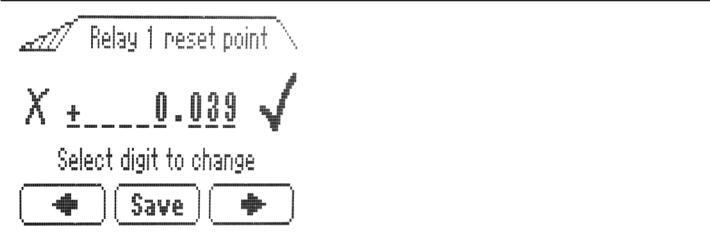



Fig. 5.4: Setpoints

Setting options

	<p>The display shows the actual pressure in the system.</p> <p>1. Touch the screen to access the menu.</p>
	<p>2. Press "Menu" to enter the settings.</p>
	<p>3. Select "Relay setup" by pressing the arrow buttons and press "Enter" to open the setting menu.</p>
	<p>4. Select "Relay 1 set point" to set the value of the pressure at which the vacuum valve will close.</p>
	<p>5. Press "Enter" to confirm.</p>
	<p>The actual vacuum setting is being displayed.</p> <p>6. Press "Change" to set another vacuum.</p>

 <p>Relay 1 set point</p> <p>X + 0.015 ✓</p> <p>Select digit to change</p> <p>← Change →</p>	7. Move to the desired digit by pressing the arrow buttons.
 <p>Relay 1 set point</p> <p>X + 0.015 ✓</p> <p>Select digit to change</p> <p>← Change →</p>	8. Press "Change" to set a new value.
 <p>Relay 1 set point</p> <p>+ 0.015</p> <p>Use +/- to change digit</p> <p>+ OK -</p>	9. Press "+" or "-" to change the value.
 <p>Relay 1 set point</p> <p>+ 0.035</p> <p>Use +/- to change digit</p> <p>+ OK -</p>	10. Press "OK" to save the entry.
 <p>Relay 1 set point</p> <p>X + 0.035 ✓</p> <p>Select digit to change</p> <p>← Save →</p>	11. Select the check mark by pressing the arrow buttons. 12. Press "Save" to save the entries and exit.
 <p>Relay setup</p> <p>^ Relay 1 mode</p> <p>Relay 1 set point</p> <p>▼ Relay 1 reset point</p> <p>↑ Enter ↓</p>	13. Select "Relay 1 reset point" by pressing the arrow buttons to set the value for the upper pressure limit at which the vacuum valve will open again.
 <p>Relay 1 reset point</p> <p>0.099</p> <p>bar</p> <p>OK Change</p>	14. The actual vacuum setting is being displayed. 15. To change that value, press "Change".

	<p>16. Select the desired digit by pressing the arrow buttons.</p>
	<p>17. Press "Change" to change the value.</p>
	<p>18. Press "+" or "-" to change the value.</p>
	<p>19. Press "OK" to save the entry.</p>
	<p>20. Select the check mark by pressing the arrow buttons. 21. Save the vacuum setting by pressing "Save".</p>
	<p>22. After 10 seconds of inactivity the display reverts to the standard screen and displays the actual pressure in the system.</p>

5.4 Selection of Distillation Temperature

In order to attain optimum distillation conditions, the energy supplied to the distillation from the bath must be dissipated again across the cooler. In order to ensure this, it is best to work according to the following rule of thumb:

Cooling water	ΔT_2	Boiling temp.	ΔT_1	Bath
max. 20 °C		40 °C		60 °C

How do you attain these conditions?

- Set the bath temperature at 60 °C.
- Adjust the cooling water. Its temperature should not be higher than 20 °C.
- Allow the cooling water to flow through the cooler at a rate of 120–150 liters/h.
- Select the working vacuum so that the boiling point 40 °C.
- Obtain the corresponding value for the vacuum from the table of solvents.

Advantages of a Bath Temperature of 60 °C :

- Evaporating flasks can be changed without any danger of scalding.
- The rate of water evaporation out of the heating bath is not yet very high.
- The energy in the heating bath is being utilized very efficiently.

The solvent should condense out in approx. 2/3 to 3/4 of the lengths of the cooling coils present.

5.5 List of Solvents

Evaporation	Boiling Point in g/mol	Spec.Gravity in g/cm ³	Vacuum in mbar		Formula in g/cm ³	Molar Mass Boiling Point at 40°C
			Energy in J/g	at 1013 mbar		
Acetic acid	C ₂ H ₄ O ₂	60.0	695	118	1.049	44
Acetone	C ₃ H ₆ O	58.1	553	56	0.790	58
<i>n</i> -Amyl alcohol, <i>n</i> -Pentanol	C ₅ H ₁₂ O	88.1	595	137	0.814	11
Benzene	C ₆ H ₆	78.1	548	80	0.877	236
<i>n</i> -Butanol, tert. Butanol	C ₄ H ₁₀ O	74.1	620	118	0.810	25
(2-Methyl-2-propanol)	C ₄ H ₁₀ O	74.1	590	82	0.789	130
Carbon tetrachloride	CCl ₄	153.8	226	77	1.594	271
Chlorobenzene	C ₆ H ₅ Cl	112.6	377	132	1.106	36
Chloroform	CHCl ₃	119.4	264	62	1.483	474
Cyclohexane	C ₆ H ₁₂	84.0	389	81	0.779	235
Diethyl ether	C ₄ H ₁₀ O	74.0	389	35	0.714	850
1,2,-Dichlorethane	C ₂ H ₄ Cl ₂	99.0	335	84	1.235	210
<i>cis</i> -1,2,-Dichlorethylene	C ₂ H ₂ Cl ₂	97.0	322	60	1.284	479
<i>trans</i> -1,2,-Dichlorethylene	C ₂ H ₂ Cl ₂	97.0	314	48	1.257	751
Diisopropyl ether	C ₆ H ₁₄ O	102.0	318	68	0.724	375
Dioxane	C ₄ H ₈ O ₂	88.1	406	101	1.034	107
DMF (Dimethylformamide)	C ₃ H ₇ NO	73.1		153	0.949	11
Ethanol	C ₂ H ₆ O	46.0	879	79	0.789	175
Ethyl acetate	C ₄ H ₈ O ₂	88.1	394	77	0.900	240
Heptane	C ₇ H ₁₆	100.2	373	98	0.684	120
Hexane	C ₆ H ₁₄	86.2	368	69	0.660	335
Isoamyl alcohol, 3-Methyl-1-butanol	C ₅ H ₁₂ O	88.1	595	129	0.809	14
Isopropyl alcohol	C ₃ H ₈ O	60.1	699	82	0.786	137
Methanol	CH ₄ O	32.0	1227	65	0.791	337
Methylene chloride, Dichloromethane	CH ₂ Cl ₂	84.9	373	40	1.327	850
Methyl ethyl ketone	C ₄ H ₈ O	72.1	473	80	0.805	243
Pentachlorethane	C ₂ HCl ₅	202.3	201	162	1.680	13
Pentane	C ₅ H ₁₂	72.1	381	36	0.626	850
<i>n</i> -Propyl alcohol	C ₃ H ₈ O	60.1	787	97	0.804	67
1,1,2,2,-Tetrachloroethane	C ₂ H ₂ Cl ₄	167.9	247	146	1.595	35
Tetrachloroethylene	C ₂ Cl ₄	165.8	234	121	1.623	53
THF (Tetrahydrofurane)	C ₄ H ₈ O	72.1		67	0.889	357
Toluol	C ₇ H ₈	92.2	427	111	0.867	77
1,1,1,-Trichlorethane	C ₂ H ₃ Cl ₃	133.4	251	74	1.339	300
Trichlorethylene	C ₂ HCl ₃	131.3	264	87	1.464	183
Water	H ₂ O	18.0	2261	100	1.000	72
Xylol (Mixture)	C ₈ H ₁₀	106.2	389			25
(o)				144	0.880	
(m)				139	0.864	
(p)				138	0.861	

Table 3: List of Solvents (CRC Handbook, 65th Ed)

5.6 Troubleshooting

	Fault	Possible cause
Bath cannot be lifted	No power supply for bath lift control defective	Contact service department
	Bath lift defective	Contact service department
	Bath too heavy, when completely filled and additional full evaporating flask is mounted	Only fill the bath to the mark at the inside of the pan
Heating does not operate	Safety temperature cutout has been activated	Reset safety temperature cutout (see Chapter 5.6)
	Level sensor is activated	Fill bath with heating medium
	PT-1000 defective (Error E0)	Check PT-1000 in the bath and replace, if necessary
	Heater coils defective	Contact service department
Rotation does not function	Rotary drive defective	Contact service department
	Rotary drive overheated	Allow it to cool off and then start it up again
Operator's panel only displays dashes	Connection to intrinsically safe operator's panel interrupted	Contact service department

Table 4: Troubleshooting

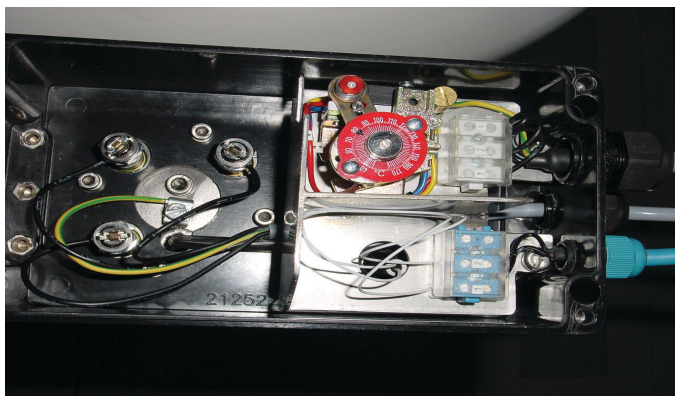

Fig. 5.2: Safety temperature cutout in the heater terminal box

5.7 Resetting the Safety Temperature Cutout

The rated cut-out temperature of the over-temperature cutout is defined by temperature class T3 and T4. The safety temperature cutout is fitted with a microswitch with a flameproof enclosure, which is in the “increased safety” terminal box.

The system is based on a liquid-filled capillary tube with a bellows fitting.

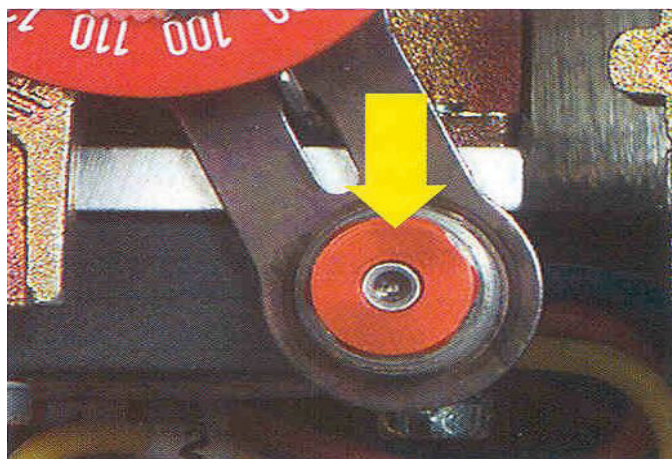

Fig. 5.3: Resetting the safety temperature cutout

Standard EN 50019 stipulates that the safety temperature limiter may only be reset using a tool (opening the terminal box) and then by hand. Automatic resetting is not possible. The temperature cutout cannot be reset until the temperature falls below the rated cut-out temperature.

5.8 Error Messages

Error messages indicate a defect on the unit and are signalled on the bath temperature display. They appear with an “E” at the start, followed by a specific number:

	E0 :	Message:	Output from the bath
			sensor not within the valid range.
		Cause:	Sensor defective or a short-circuit has occurred.
		Action:	The bath heater is switched OFF. The bath is lowered. Rotation stops.
		Acknowledgment:	Switch the unit OFF.
E1 :		Message:	The level sensor is not covered.
		Cause:	No heating medium in the bath.
		Action:	Bath heater is switched OFF. Bath is lowered.
		Acknowledgment:	Switch the unit OFF, refill bath.
E2 :		Message:	The bath is not reaching the intended maximum height.
		Cause:	The motor is defective or blocked. No voltage.
		Action:	The lift motor switches OFF. Rotation and heating continue.
		Acknowledgment:	Switch the unit OFF.
E3 :		Message:	The rotary drive does not reaching the required speed, or is turning too quickly.
		Cause:	Drive defective. Mechanical blocking. No power. Semi-conductor relay defective.
		Action:	Bath heater is switched OFF. Bath is lowered.
		Acknowledgment:	Switch the unit OFF.
E4 :		Message:	Battery voltage too low. Displayed only when starting the unit.
		Cause:	PB battery defective
		Action:	None
		Acknowledgment:	Press any button.
E5 :		Message:	EEPROM error.
		Cause:	Hardware defect.
		Action:	None.
		Acknowledgment:	Press any button. Work can then be continued, but a Service technician must be notified of the problem.
E27 :		Message:	Communication with control panel broken.
		Cause:	Cables or plugs defective.
		Action:	Heder and Rotation are switched off, bath lowers.
		Acknowledgment:	Switch the unit off.
E28 :		Message:	Replay of heater down.
		Cause:	Overtemperature cutoff is active.
		Action:	Heder and Rotation are switched off, bath lowers.
		Acknowledgment:	Reset the overtemperature cutoff. (see chapter 5.6)

Table 5: Error messages



To let all possible error messages appear, the device must be shut off and on at least once per 24 h.

6 Maintenance

Please note all rules aimed at keeping the rotary evaporator in a functional condition. These also include periodic cleaning and inspection for any damage that might have occurred.



Make certain that supply of power to the unit has been interrupted before doing any maintenance work on the unit. Always support the bath from below, on the underside of the bath whenever doing any repair work.

6.1 Cleaning

Use commercially available cleaning agents to clean the glassware.

Merely wipe the housing off with a damp cloth (without using any organic solvents).

Use a commercially available de-liming agent to dissolve residues of lime in the bath and flush the bath out well.

Vacuum seal

The vacuum seal should be cleaned according to how much it is used but every three months as a minimum. See Chapter 6.5 for instructions on how to remove it.

Wipe the sealing lip with a soft dry cloth. Clean the contact surface of the vapor duct.



Regular care of the seal extends its service life.



Fig. 6.1: Taking apart the snap flange coupling

6.2 Dismantling/Assembling the Flask Snap Flange Coupling

Dismantling the snap flange coupling

- Close the two segments of the snap flange coupling.
- Turn the snap flange coupling by 180°, until the closure faces down.
- Have Tool No. 20075 ready at hand.
- Reopen the closure.
- Lift the 1st segment of the snap flange coupling to open it.
- Lift the 2nd segment of the snap flange coupling to open it.
- With three fingers at the tip, reach under the middle segment and raise it up.
- Insert Tool No. 20075 in at the side, between the lugs on the positional lock. Turn lightly until the pin becomes unlatched. Take the snap flange coupling assembly off.
- Clean the snap flange coupling.



Fig. 6.2: Assembling the snap flange coupling

Assembling the snap flange coupling

- Insert the snap flange coupling from above, until the pins in the lock latch into the hole on the lug.
- Close the two segments of the snap flange coupling.
- Turn the snap flange coupling again by 180°, until the closure lies at the top.
- Lift the two segments of the snap flange coupling to open them.



Fig. 6.3: Removing the evaporating flask seal

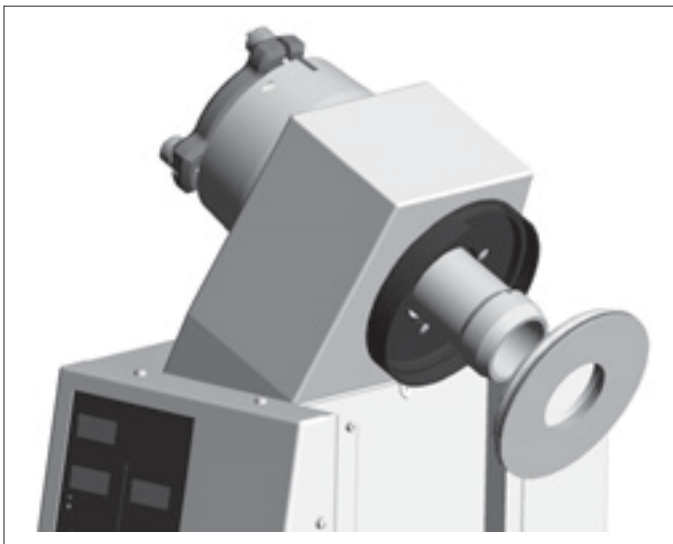

Fig. 6.4: Inserting the evaporating flask seal

6.3 Removing/Inserting the Evaporating Flask Seal

Removing the evaporating flask seal

- Seal the holder for the seal by 180°, until the opening faces up.
- Take hold of the seal with both hands, from above and from the front, and pull it out slowly.
- Tilt the seal slightly and carefully pull it all the way out. Be careful not to damage the glass centering bulge when doing so.
- Remove the vapor duct.

Inserting the evaporating flask seal

- Insert the vapor duct.
- Insert the seal. Using gentle pressure, shove it across the lock preventing it from twisting out of position, and then shove it all the way in. Press it with both thumbs until it latches in position.

6.4 Changing the Seals on the Distribution Head

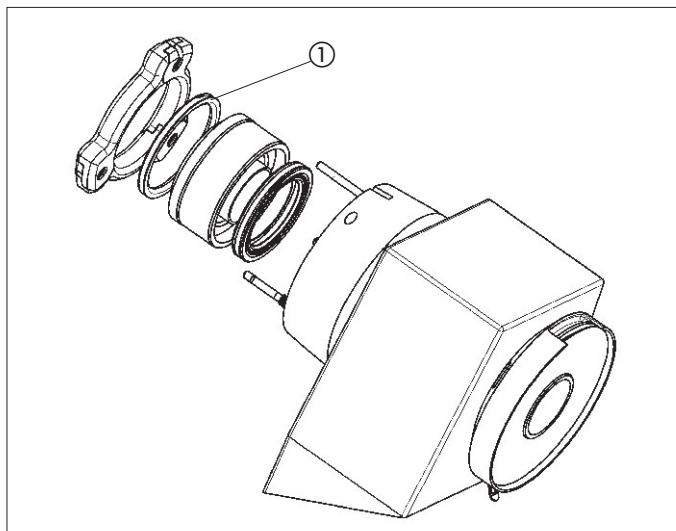

Fig. 6.5: Replacing the seal in the distribution head

- Open the DN70 EasyClamp by releasing the knurled nuts on all 3 bolts, but do not screw the nuts completely off.
- Tilt the top bolt out toward the back.
- Open the upper and lower EasyClamp segments and carefully lift the distribution head off the glass assembly.
- Take out the seal ① laid in at the front and replace it.

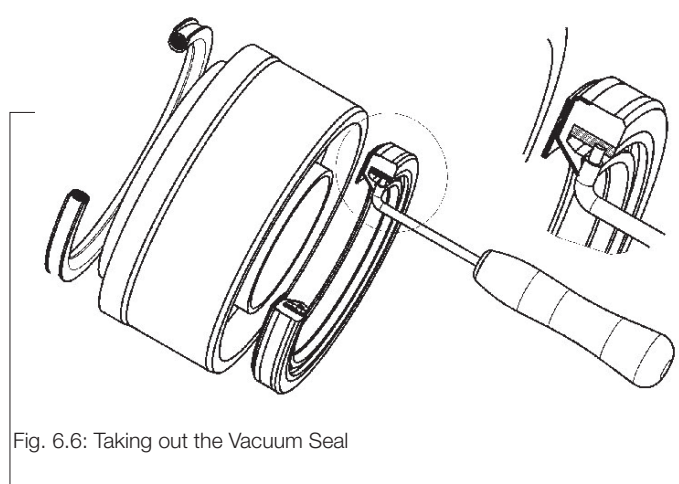

Fig. 6.6: Taking out the Vacuum Seal

6.5 Installing and Removing the Vacuum Seal

During the running-in phase, which lasts approx. 10 hours, the seal may show signs of increased wear. This is normal for a PTFE seal.

- Remove the DN70 EasyClamp completely and take off the distribution head.
- Pull the cylindrical seal holder out and turn it over.
- Insert Tool No. 20075 into the metal guide on the seal and pull the seal out.
- Put in the new seal with the dark scraper ring facing the inside and the metal guide ring facing outward.
- Insert the cylinder with the seal at the back lying on the in-side.
- Insert the seal at the front.
- Provisionally install the EasyClamp using 2 bolts.
- Set the distribution head of the glass assembly on top of the seal.
- Close the segments of the EasyClamp. Flip the top bolt up and in, and hand-tighten all 3 knurled nuts.

The unit should be tested for leaks each time the vacuum seal has been removed.

6.6 Testing for Leaks

With the assembled rotary evaporator in a clean and dry

condition, test it to ensure that the vacuum system is free of leaks. To do this, evacuate the unit to below 100 mbar and then close the vacuum line. The rate of pressure rise must not exceed 3 to 5 mbar per 15 minutes.

A greater pressure rise indicates a leakage in the system. In such a case, recheck all EasyClamp connections and all valves.

6.7 Customer Service

No intervention on or in the unit is permissible except when done by authorized Service personnel. These are individuals with a well-backed technical professional training and knowledge of the dangers that result from a failure to observe the safety precautions required. BUCHI's Customer Service representatives have available to them a Service Manual specific to the unit in question. That manual is issued only to authorized Service personnel.

The addresses of BUCHI's official Customer Service representatives are shown on the back cover of this Operation Manual. Please turn to these representatives should you have any malfunctions, technical questions, or problems in using the unit.

BUCHI's Customer Service Dept. will be ready and happy to offer the following services:

- Spare parts service
- Repair service
- Maintenance service
- Technical consultation.

7 Taking out of Operation

Remove all hazardous materials and clean the unit thoroughly.



This prevents any risk that individuals could suffer injuries due to contact with hazardous materials.

7.1 Storage

Always store the unit and spare parts for it in a clean and dry location.

7.2 Packing / Transport

The original packing has been specially designed for transporting the unit and the glass parts for it. Use only the original packing materials for any further transport.

7.3 Waste Disposal

Table 9 in the Appendix, Chapter 9, contains a list of the materials, including their material codes, used for the most important components of the unit. This list has been provided in order to enable environmentally correct disposal of the rotary evaporator. It ensures that the parts can be separated and sent for appropriate recycling. Please refer to the pertinent guidelines when disposing of electrical parts. In addition, observe all regional and local laws covering waste disposal.

Used batteries may be returned directly to your BUCHI representative for disposal.

8 Spare Parts and Accessories

Only original BUCHI accessories and spare parts ensure safe

operation and a proper functioning of the unit. The use of spare parts and accessories other than those from BUCHI is permissible only with prior approval of the manufacturer. The Spare Parts Catalog may be used for purposes of assembly and disassembly only in conjunction with the corresponding Chapters 4 and 7 in this Operation Manual. Dis-closure and distribution to third parties, and manufacturing based on this manual are strictly forbidden.

Copyright by BÜCHI Labortechnik AG. All rights reserved.

8.1 Spare Parts, Glass Assemblies R, RB

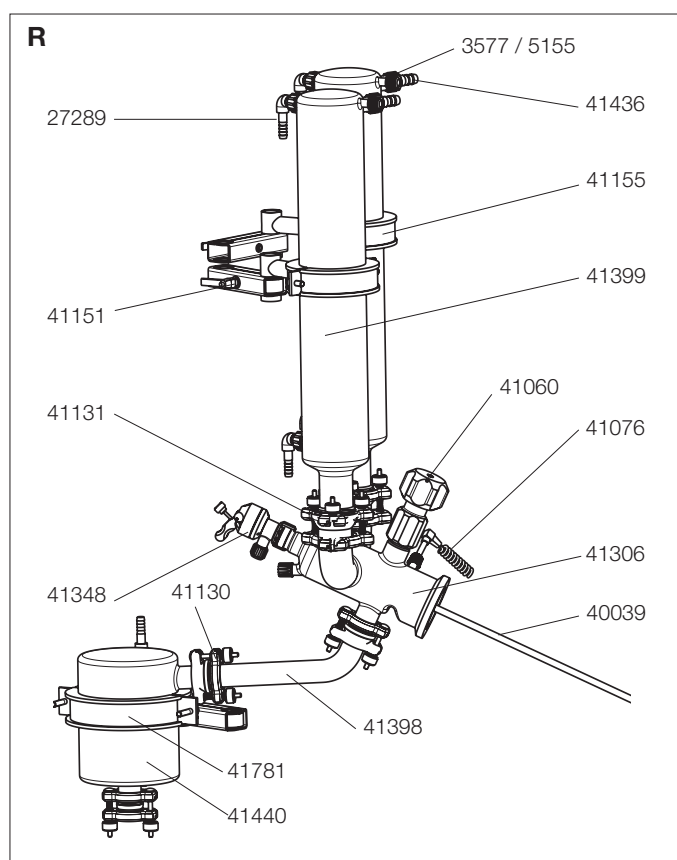

Component	Ordering No.
Threaded sleeve Sv1 22	03577
Seal Sv1 22 Id 17 PTFE	05155
PTFE hose, Outer Diam. 10	40039
Screwed fitting Sv1 22	27289
Temperature sensor B, complete	41076
Glass holder B, complete	41120
EasyClamp, DN25	41130
EasyClamp, DN40	41131
Pivoting clamp, complete	41151
Glass holder, complete	41155
Set of bolts for EasyClamp, DN25	41240
Set of bolts for EasyClamp, DN40	41241
Distribution piece "R"	41306
Industrial tap, large	41060
Inlet valve, complete	41348
Connection DN 25	41398
Cooler, 3-coil, closed	41399
Hose nipple	41436
Distillate cooler	41440
Cooler Bullfrog, closed	41458
Support distillate condenser	41781

Table 6: Spare parts, Glass Assemblies R, RB

8.2 Spare Parts, Glass Assemblies D, D3

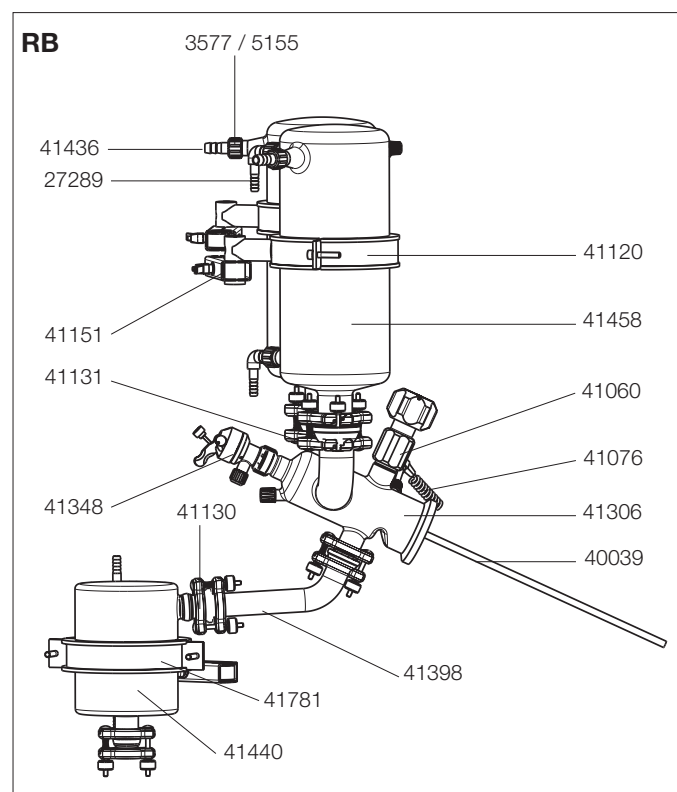
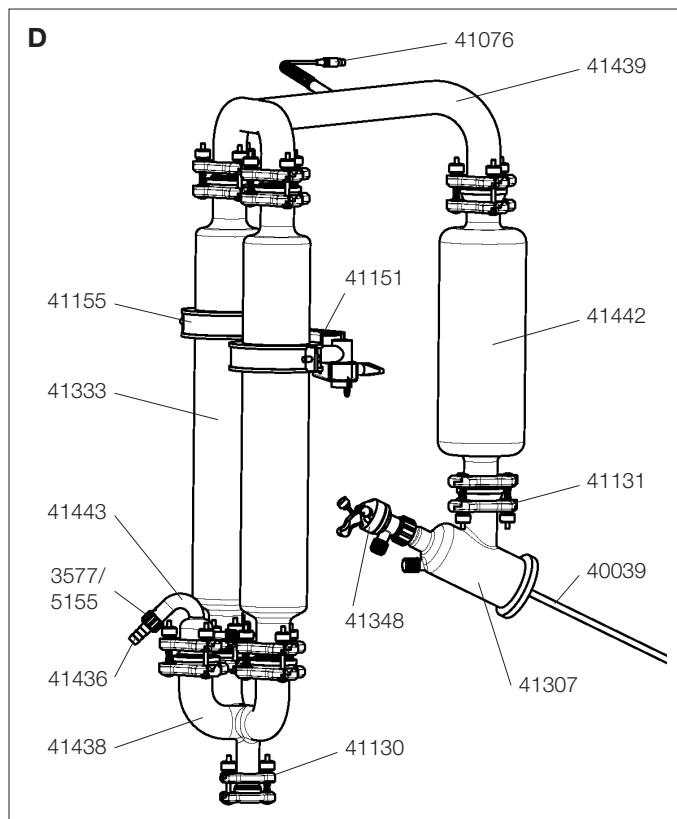

Fig. 8.1: Spare parts: Reflux glass assembly



Component	Ordering No.
Threaded sleeve Sv1 22	03577
Seal Sv1 22 Id 17 PTFE	05155
PTFE hose, Outer Diam. 10	40039
Screwed fitting Sv1 22	27289
Temperature sensor B, complete	41076
EasyClamp, DN25	41130
EasyClamp, DN40	41131
Pivoting clamp, complete	41151
Glass holder, complete	41155
Set of bolts for EasyClamp, DN25	41240
Set of bolts for EasyClamp, DN40	41241
Distribution piece "D"	41307
Cooler, 3 coil	41333
Inlet valve, complete	41348
Cooler, 3-coil, closed	41399
Hose nipple	41436
Frame DN25/3xDN40	41438
U-frame	41439
Expansion vessel	41442
Vacuum connector	41443
Extension	41270

Table 7: Spare parts, Glass Assemblies D, D3

8.3 Spare Parts, Drip Tray

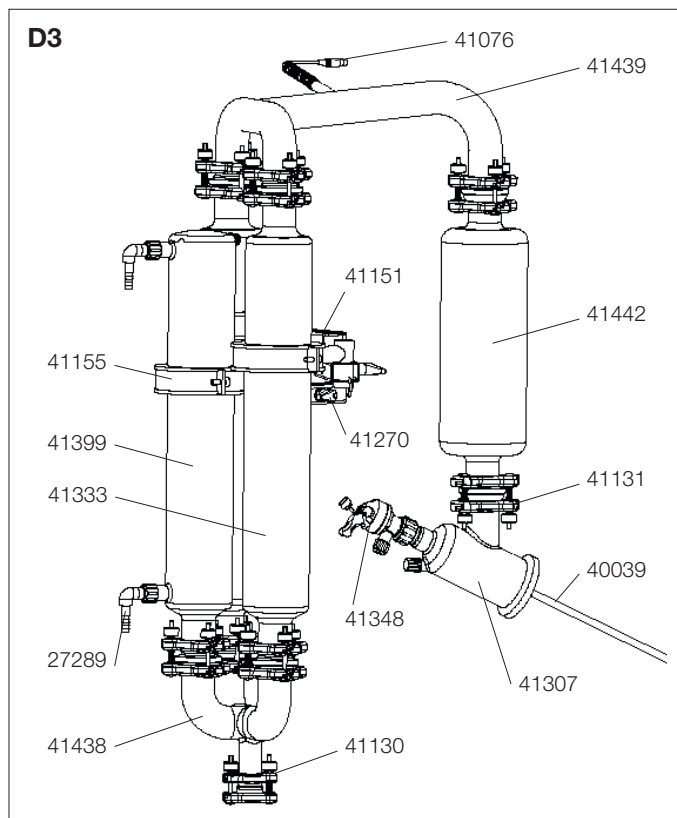
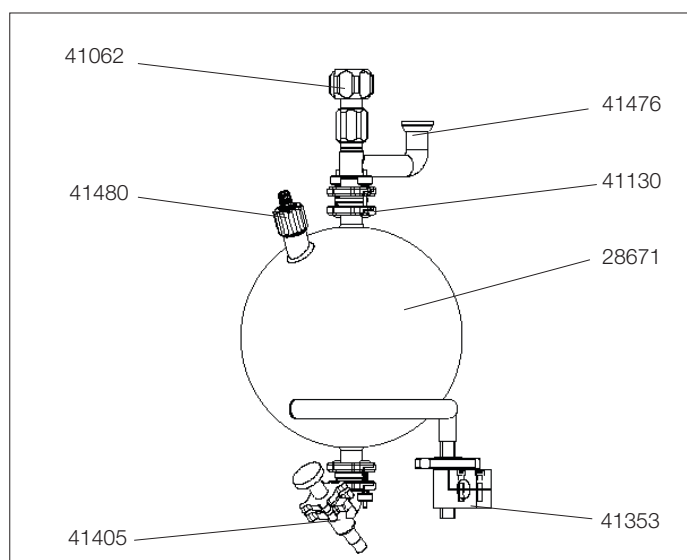
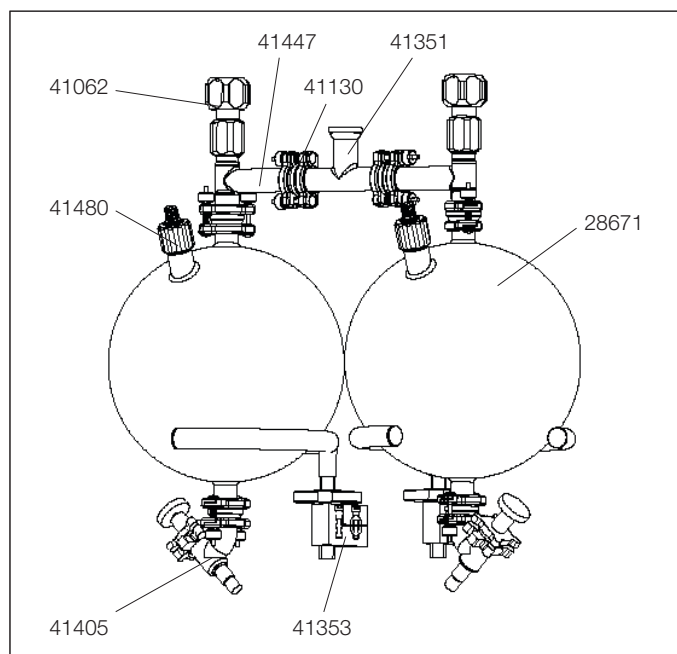

Fig. 8.2: Spare parts: Descending glass assembly

**Component****Ordering No.****Single receiver**

Receiving flask 20 lt.	28671
EasyClamp, DN25	41130
Industrial tap, small	41062
Spindle support	41353
Angle seat valve, special	41405
Branching piece R-250	41476
Ventilation duct, complete	41480

**Interchangeable receiver**

Receiving flask 20 lt.	28671
EasyClamp, DN25	41130
Industrial tap, small	41062
T-piece DN 3x40	41351
Spindle support	41353
Angle seat valve, special	41405
Branching piece 1	41447
Ventilation duct, complete	41480

8.4 Seals, Tools

Fig. 8.3: Spare Parts: Drip tray

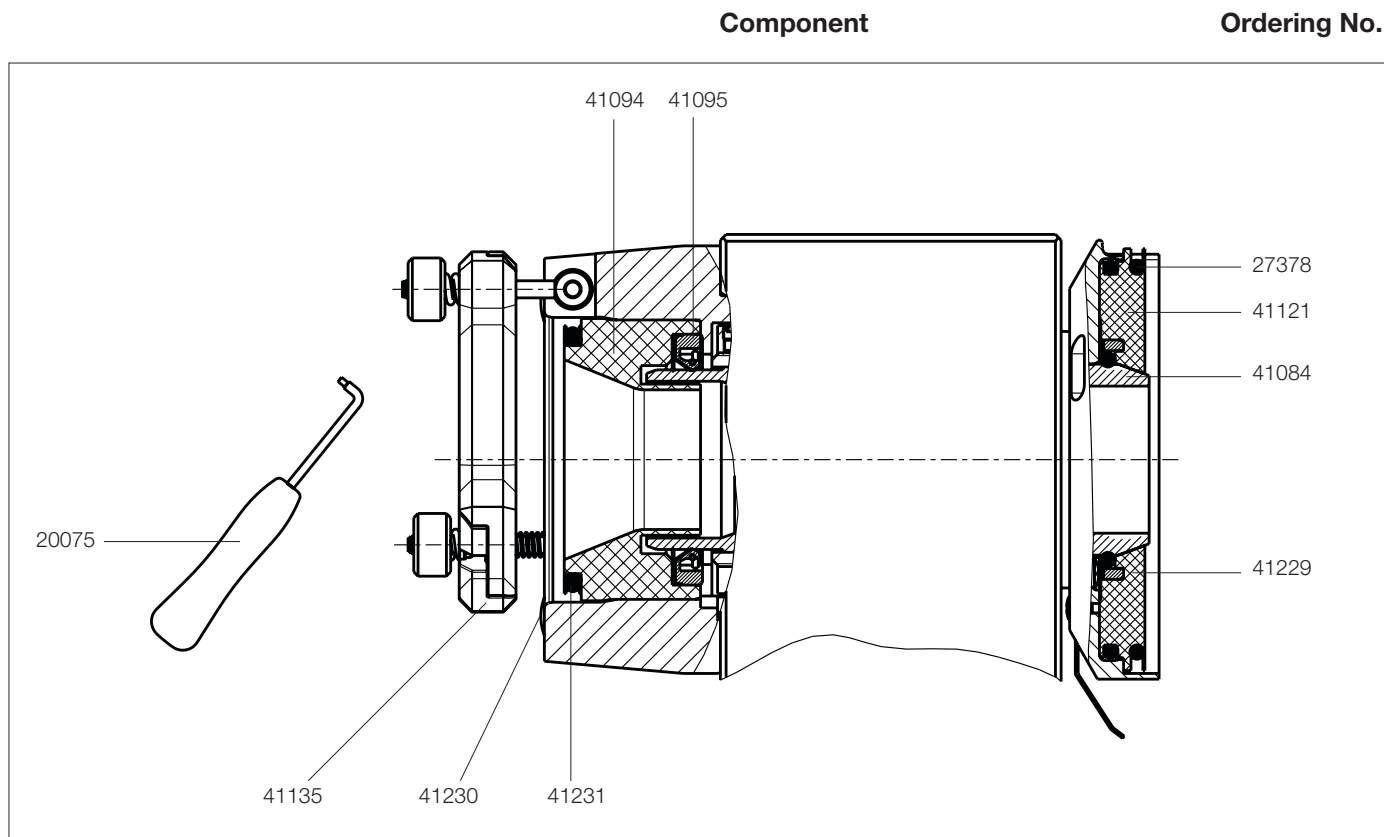

Fig. 8.4: Sealing elements

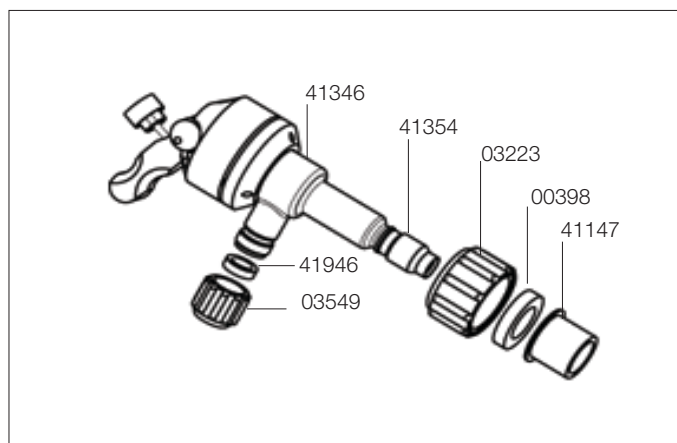

Fig. 8.5: Inlet valve, complete

Sealing elements

Support ring inlet valve	41147
Seal SVL 30	00398
Screw Cap SVL 30	03223
Screw Cap SVL 15	03549
Seal tool	20075
O-ring 130x5.0 Fpm70	27378
Vapor duct	41084
Seal holder	41094
Vacuum seal	41095
Evaporating flask seal, complete	41121
EasyClamp element, DN70	41135
Set of 5 O-rings 64x5.0	41229
Set of 10 cover caps, D11 Pa	41230
Set of distribution head sealings	41231
Glass body	41346
Inlet valve, complete	41348
Connection, PTFE	41354
PTFE bellow	41388
Set of 5 SVL 15 seals	41946

Component	Ordering No.
-----------	--------------

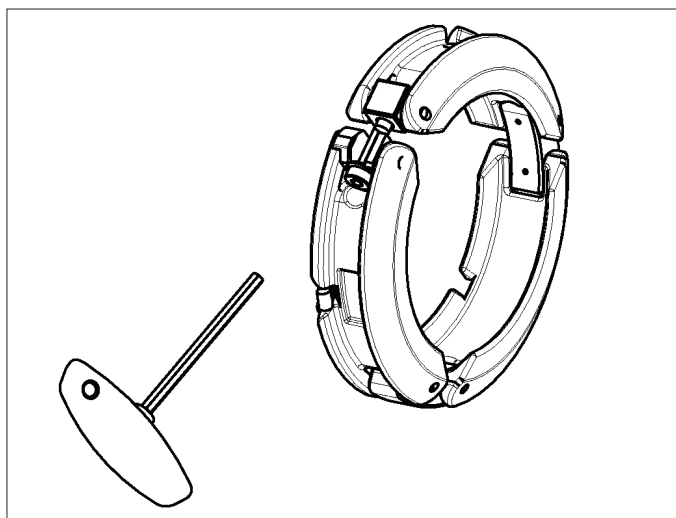

Fig. 8.6: Snap flange coupling complete with tool

Snap flange coupling, complete	41415
Screw cap	41416
Tool	41472

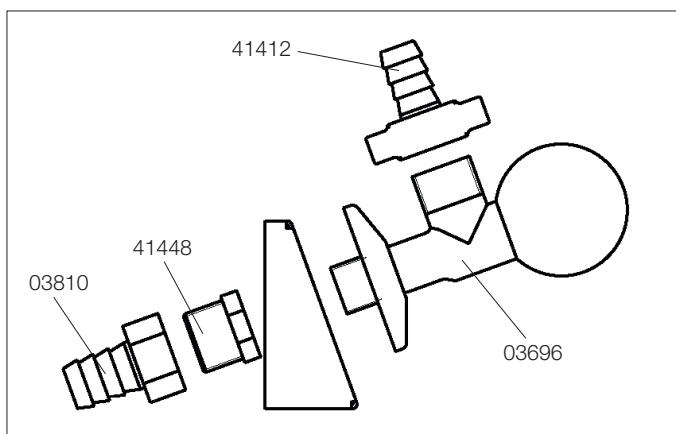

Fig. 8.7: Cooling water tap, complete

Cooling water tap, complete	03693
Nipple $\frac{3}{4}$ " x 20 mm	03810
Nipple $\frac{3}{4}$ " x 16 mm	41412
Reducer $\frac{1}{2}$ " x $\frac{3}{4}$ "	41448

8.5 Accessories

Component	Ordering No.
-----------	--------------

Cover for evaporating flask, PE	11057349
---------------------------------	-----------------

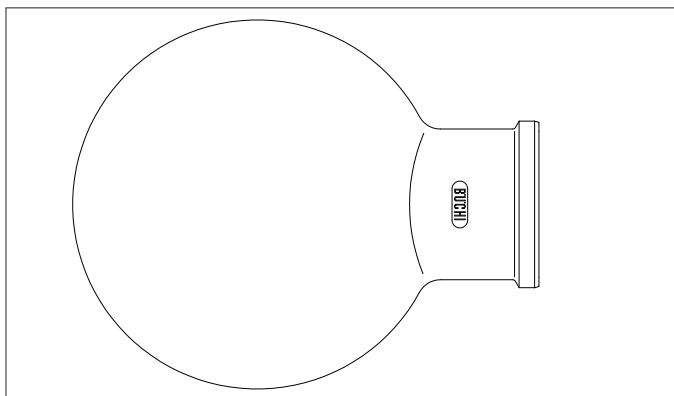

**Kolben**

Evaporating flask 20 ltr.	41432
---------------------------	--------------

Evaporating flask 50 ltr.	41339
---------------------------	--------------

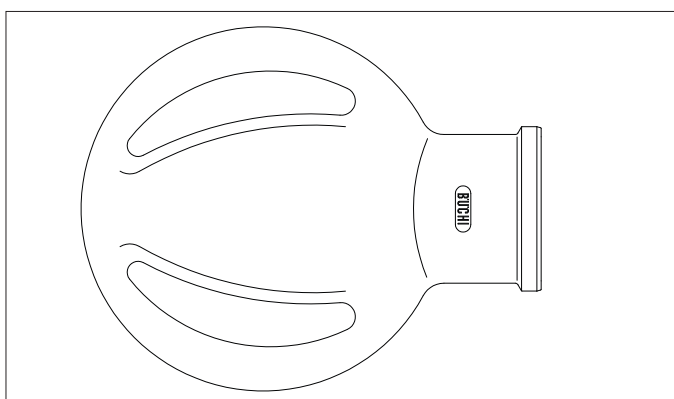

Drying flask 20 ltr.	41393
----------------------	--------------

Drying flask 50 ltr.	41394
----------------------	--------------

This special flask is particularly suited for drying powdery substances or a homogeneous mixture of solid products. The baffles attached on the circumference of the flask ensure an intensive circulation of the contents inside the flask.

Fig. 8.9: Flasks

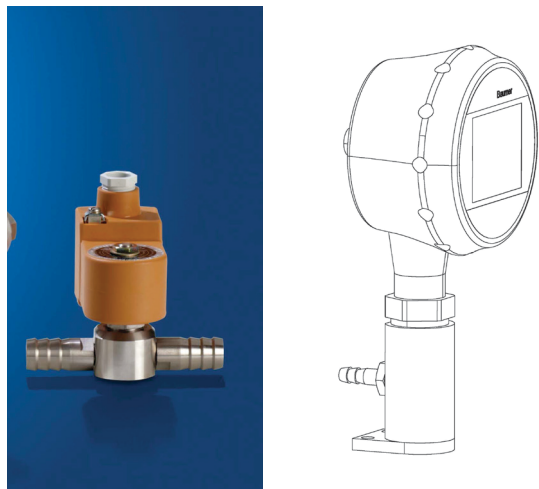

Fig. 8.11: Valve body complete and Controller Ex

Vacuum Controller (EX)

Component	Ordering No.
Vacuum controller Ex, complete	11060831
Valve body, stainless, complete	41424
In-line valve 24 V (encapsulated)	41488

8.6 Hose Connections

Component	Ordering No.
Water:	
PVC hose, ID 10 mm	27146
PVC hose, ID 14 mm	17383
Y-piece, 12 mm / 16 mm	41473
Pressure side (upstream of reduction valve)	
Softaflex, ID 8 mm	04113
Softaflex, ID 19 mm	37617
Vacuum:	
Spiralflex hose, ID 16 mm	41441
tube synthetic rubber, Ø6/13mm, black, per m	11063244
Y-piece, Outer Diam. 16 mm	41449
T-reducer, 16 / 8 mm	41474
Product:	
PTFE hose, Outer Diam. 10 mm	27277
PTFE hose, Outer Diam. 10 mm conductive	40039

9 Appendix

9.1 Technical Data

R-250 EX

Power consumption	7.5 k
Electrical requirements	400 - 440 V (3P +N), 50 / 60 Hz
Site condition	maximum relative humidity 80% for temperatures up to 31° C decreasing linearly to 50% relative humidity at 40° C
Evaporator capacity	31 litres of acetone per hour, different for other solvents depending on the heat of evaporation
Rotation drive	Induction motor, with explosion protection to EEx de II C T4
Speed control	Frequency converter, 5-100 rpm
Control	Flameproof encapsulation to EEx d II C T4
Operation	Intrinsically safe control panel EEx ia II C T4
Heating capacity	6.6 kW, specific heat transferatio <3W/cm ²
Bath dimensions	Diameter 610 mm, 320 mm depth
Bath pan	Stainless steel X2CrNiMo17 13 2 (1.4404 or 316L)
Bath heater control	Electronic, with PT-1000, control accuracy ± 2°C
Bath temperature range	0° - 150°C
Bath level monitor	Liquiphant, EEx d II C T4
Overheating protection	Separate monitoring circle, mechanically reset, additional security switch off exceeding the set point by 15° C
Bath lift	24 V DC motor 24V with linear drive, IP 65, EEx d II C T4
Battery	Accumulator PB, 12V
Vapor temperature measurement	PT-1000
Displays	Vapour temperature, bath temperature, rotation speed, vacuum pressure
Aeration	By aeration plug
Installation category	II
degree of pollution	2
Cooling area	Two or three condensate coolers of 0,6 m ² each, distillate cooler 0,08 m ²
Vacuum pump	Recommended suction output in excess of 5 m ³
Cooling water consumption	200 – 400 l / h, 2.7 bar abs. maximum (without pulsation)
Weight	250 kg without glass
Dimensions	See relevant Chapter

Table 8: Technical Data

9.2 Materials Used

Part	Material	
	Description	Code
Chassis	X5CrNi 18 10	1,4301 or 304
Bath pan	X2CrNiMo 17 13 2	1,4404 or 316L
Glass	Borosilicate 3,3	
Seals	Polytetrafluorethylene	PTFE
Taps	Polytetrafluorethylene	PTFE

Table 9: Materials Used



THE EXPLOSIONPROOFING COMPANY



EU-Konformitätserklärung
Déclaration UE de conformité
EU Declaration of conformity

Wir / Nous / We,

thuba Ltd.
PO Box 4460
CH-4002 Basel

Production
Stockbrunnenrain 9
CH-4123 Allschwil

erklären in alleiniger Verantwortung, dass die
déclarons de notre seule responsabilité que les
bearing sole responsibility, hereby declare that the

Rotavapor R250Ex

den grundlegenden Sicherheits- und Gesundheitsschutzanforderungen nach Anhang II der untenstehenden
Richtlinie entspricht.

répond aux exigences essentielles en ce qui concerne la sécurité et la santé fondamentales selon l'annexe II des
directives suivantes.

satisfies the fundamental health and safety protection requirements according to Annex II of the directive named below.

Bestimmungen der Richtlinie
Désignation de la directive
Provisions of the directive

Titel und/oder Nummer sowie Ausgabedatum der Normen
Titre et/ou No. ainsi que date d'émission des normes
Title and/or No. and date of issue of the standards

**2014/34/EU: Geräte und Schutzsysteme zur
bestimmungsgemässen Verwendung in
explosionsgefährdeten Bereichen**

*2014/34/UE: Appareils et systèmes de protection
destinés à être utilisés en atmosphère explosible*

2014/34/EU: Equipment and protective systems
intended for use in potentially explosive atmospheres

EN IEC 60079-0:2018
EN 60079-1:2014-10
EN 60079-7:2015-12+A1:2018-01
EN 60079-11:2012-01
EN ISO 80079-36:2016
EN ISO 80079-37:2016
EN 60079-14:2014-03
EN 60079-17:2014-03
EN 60529:1991-10+A1:2000-A2:2013
EN 60034-1:2010
EN 60034-5:2001+A1:2007
EN 60034-6:1993
EN 60034-7:1993+A1:2001
EN 60034-8:2007+A1:2014
EN 60034-9:2005+A1:2007
EN 60034-12:2002+A1:2007
EN 60034-14:2004+A1:2007
EN 60947-8:2003+A1:2006+A2:2012
EN 60204-1:2006-06+A1:2010-05
EN 61439-1:2011-10
EN 61439-2:2011-10
EN 60519-1:2015
EN 60519-2:2006
EN 60730-1:2011
EN 60730-2-9:2010

2014/30/EU: Elektromagnetische Verträglichkeit

2014/30/UE: Compatibilité électromagnétique

2014/30/EU: Electromagnetic compatibility

EN 60947-1:2007-07+A1:2011-01+A2:2014-11
EN 61326-1:2013

Folgende benannte Stelle hat die Bewertung des Moduls
«Qualitätssicherung Produktion» nach der Richtlinie
2014/34/EU Anhang IV durchgeführt:

*L'organe reconnu ci-après a procédé à l'évaluation de la conformité
prescrite par la directive 2014/34/UE de l'annexe IV:*

The following notified body has carried out the conformity
assessment procedure according to Directive 2014/34/EU,
Annex IV:

DEKRA Testing and Certification GmbH
0158
Dinnendahlstrasse 9
D-44809 Bochum

Basel, 14. Juli 2021

Ort und Datum
Lieu et date
Place and date

Peter Thurnherr

Geschäftsführender Inhaber, Elektroingenieur FH
Administrateur délégué, ingénieur HES
Managing Proprietor, B. Sc. Electrical Engineer

BUCHI Affiliates:

Europe

Switzerland/Austria

BÜCHI Labortechnik AG
CH – 9230 Flawil
T +41 71 394 63 63
F +41 71 394 64 64
buchi@buchi.com
www.buchi.com

Italy

BUCHI Italia s.r.l.
IT – 20010 Cornaredo (MI)
T +39 02 824 50 11
F +39 02 575 12 855
italia@buchi.com
www.buchi.com/it-it

Benelux

BÜCHI Labortechnik GmbH
Branch Office Benelux
NL – 3342 GT Hendrik-Ido-Ambacht
T +31 78 684 94 29
F +31 78 684 94 30
benelux@buchi.com
www.buchi.com/bx-en

Russia

BUCHI Russia/CIS
RU – 127006 Moscow
T +7 495 36 36 495
russia@buchi.com
www.buchi.com/ru-ru

France

BUCHI Sarl
FR – 91140 Villebon-sur-Yvette
T +33 1 56 70 62 50
F +33 1 46 86 00 31
france@buchi.com
www.buchi.com/fr-fr

Spain

BUCHI Ibérica S.L.U.
ES – 08960 Barcelona
T +34 936 06 8010
iberica@buchi.com
www.buchi.com/es-es

Germany

BÜCHI Labortechnik GmbH
DE – 45127 Essen
T +800 414 0 414 0 (Toll Free)
T +49 201 747 49 0
F +49 201 747 49 20
deutschland@buchi.com
www.buchi.com/de-de

United Kingdom

BUCHI UK Ltd.
GB – Suffolk CB8 7SQ
T +44 161 633 1000
F +44 161 633 1007
uk@buchi.com
www.buchi.com/gb-en

NIR-Online

Germany

NIR-Online GmbH
DE – 69190 Walldorf
T +49 6227 73 26 60
F +49 6227 73 26 70
nir-online@buchi.com
www.nir-online.de

America

Brazil

BUCHI Brasil Ltda.
BR – Valinhos SP 13271-200
T +55 19 3849 1201
F +55 19 3849 2907
brasil@buchi.com
www.buchi.com/br-pt

USA/Canada

BUCHI Corporation
US – New Castle, DE 19720
T +1 877 692 8244 (Toll Free)
T +1 302 652 3000
F +1 302 652 8777
us-sales@buchi.com
www.buchi.com/us-en

Asia

China

BUCHI China
CN – 200233 Shanghai
T +86 21 6280 3366
F +86 21 5230 8821
china@buchi.com
www.buchi.com/cn-zh

India

BUCHI India Private Ltd.
IN – Mumbai 400 055
T +91 22 667 75400
F +91 22 667 18986
india@buchi.com
www.buchi.com/in-en

Indonesia

PT. BUCHI Indonesia
ID – Tangerang 15332
T +62 21 2222 9478
F +62 21 5568 7906
indonesia@buchi.com
www.buchi.com/id-in

Japan

Nihon BUCHI K.K.
JP – Tokyo 110-0008
T +81 3 3821 4777
F +81 3 3821 4555
nihon@buchi.com
www.buchi.com/jp-ja

Korea

BUCHI Korea Inc.
KR – Seoul 153-782
T +82 2 6718 7500
F +82 2 6718 7599
korea@buchi.com
www.buchi.com/kr-ko

Malaysia

BUCHI Malaysia Sdn. Bhd.
MY – 47301 Petaling Jaya,
Selangor
T +60 3 7832 0310
F +60 3 7832 0309
malaysia@buchi.com
www.buchi.com/my-en

Singapore

BUCHI Singapore Pte. Ltd.
SG – Singapore 609919
T +65 6565 1175
F +65 6566 7047
singapore@buchi.com
www.buchi.com/sg-en

Thailand

BUCHI (Thailand) Ltd.
TH – Bangkok 10600
T +66 2 862 08 51
F +66 2 862 08 54
thailand@buchi.com
www.buchi.com/th-th

BUCHI Support Centers:

South East Asia

BUCHI (Thailand) Ltd.
TH-Bangkok 10600
T +66 2 862 08 51
F +66 2 862 08 54
bacc@buchi.com
www.buchi.com/th-th

Middle East

BÜCHI Labortechnik AG
UAE – Dubai
T +971 4 313 2860
F +971 4 313 2861
middleeast@buchi.com
www.buchi.com

Latin America

BUCHI Latinoamérica S. de R.L. de C.V.
MX – Mexico City
T +52 55 9001 5386
latinoamerica@buchi.com
www.buchi.com/es-es

We are represented by more than 100 distribution partners worldwide.
Find your local representative at: www.buchi.com